

Design and Implementation of a Wearable Artificial Kidney Prototype for Home Treatment

Ramzi Qawasma, Abdel-Karim Daud

Abstract—Hemodialysis is a life-preserving treatment for a number of patients with kidney failure. The standard procedure of hemodialysis is three times a week during the hemodialysis procedure, the patient usually suffering from many inconvenient, exhausting feeling and effect on the heart and cardiovascular system are the most common signs. This paper provides a solution to reduce the previous problems by designing a wearable artificial kidney (WAK) taking in consideration a minimization the size of the dialysis machine. The WAK system consists of two circuits: blood circuit and dialysate circuit. The blood from the patient is filtered in the dialyzer before returning back to the patient. Several parameters using an advanced microcontroller and array of sensors. WAK equipped with visible and audible alarm system to aware the patients if there is any problem.

Keywords—Artificial kidney, Home dialysis, Renal failure, Wearable Artificial kidney.

I. INTRODUCTION

NORMAL human beings have two kidneys, a healthy kidney is basically a filtering system which removes waste products, toxic substances and excess fluids from the blood in the form of urine [1]. Renal failure (also kidney failure or renal insufficiency) is a medical condition in which the kidneys fail to filter waste products and excess fluids adequately from the blood, this occur due to several factors and causes some symptoms [2], [3].

Renal therapy is a life-supporting treatment for renal failure, which includes: Renal Transplantation and Hemodialysis. Renal transplantation is the organ transplant of a kidney into a patient with end-stage of renal disease. Kidney transplantation is typically classified as deceased-donor (formerly known as cadaveric) or living-donor transplantation depending on the source of the donor organ[4], in addition, the donor and patient must pass the compatibility test. Until finding a donor, the patient tends to use the hemodialysis process. Hemodialysis is the process that involves the removal of chemical substances from the blood by passing it through tubes surrounded by a semi permeable membrane[5].

Despite all of the advantages of the previous therapies, there are some disadvantages if they performed at hospital[6]; the patients need to visit the medical center and spend more than five hours every three times a week, so that patients can't able lead a normal life style due to the frequent visit to center, other challenge is the infection during the treatment because of the inefficiency of sterilization and cleaning processes and finally the relatively high cost of the treatment procedure

specially for those people in developing contraction. Due to the disadvantages of the previous methods it's necessary to find an alternative solution for blood filtration, which is WAK to perform hemodialysis at home conditions.

Home dialysis allows the patient to control the procedure. The user can choose treatment time and duration taking in consideration the other life activities and commitments WAK gives the patient the ability overcome the difficulties of hemodialysis in the hospitals and medical centers.

The design of wearable artificial kidney prototype for filtering the blood at home conditions, should satisfy the following requirements: the physical size must be small, the weight must be light and the power supply of the system must sufficient for operating the system for 4 hours. The WAK includes the following subcircuits: 1. Flow control section with three pumps for blood and dialysate solution, 2. Air bubble detection module, 3. Temperature measurement circuit for dialysate solution, 4. Blood pressure measurement circuit, 5. Blood leak detection module, 6. Visible and audible alarm circuits, 7. Conductivity measurement circuit for dialysate solution.

II. METHODOLOGY

The patient's blood from an artery is continuously pumped to the dialyzer by a DC peristaltic pump to ensure high blood flow rates. Before the blood enters the dialyzer, heparin is added to prevent clotting during the hemodialysis procedure [7]. The blood flowing through the dialyzer will pass across 20000 open ended and semipermeable tubes of 100-micron ID and 30 cm long. While the dialysate solution enters around these fibers a pressure gradient across the membrane which separates the dialysate solution and the blood compartments will occur, beside that a proper flow of compounds out of and into the blood will happen, the blood is passing through several stages of monitoring before returning back to the patient; the first stage is an air bubble detection using an ultrasonic sensor to detect if there is any air bubble inside the filtered blood, in the case of the bubble detection the alarm system will be activated, the valve in the blood line will be closed and the blood pump is stopped to prevent blood containing air bubbles from entering the body which may causing a death.

The pressure monitoring and controlling will be done by using an SCX15DNC pressure sensor that measures the blood pressure before entering the patient's body. If the measured pressure is out of the normal range [350-450 mmHg][8]-[10], the alarm system will be activated, so that the patient can check needle position.

On the other hand, treated water inflows from Reverse Osmosis (RO) system into the dialysate tank to obtain a fixed conductivity of dialysate solution 14 mS/cm[11], which is measured using a conductivity cell to insure a high efficiency of the dialysis process. Then the dialysate solution enters the dialyzer in opposite direction of blood flow, the dialysis process is totally completed by the dialyzer based on two functions; removed of waste products by diffusion and convention-known and removed of excess water by ultrafiltration strategy. The excess fluids and waste products are removed from blood to dialysate solution. The dialysate solution continues to flow to the drain by a negative pressure created by the ultrafiltration pump [2].

A blood leak detector is placed on the drain line, which detects the presence of blood component in the dialysate solution flowing to the drain. In the case of blood leak the alarm system will be activated and the system will be stopped until the dialyzer is changed or the condition is corrected. The last stage is the temperature monitoring using an LM35 temperature sensor that measures the temperature of the dialysate solution to control the blood temperature via heat transfer.

An advanced microcontroller -Arduino DUE- is used in the designed WAK, taking all the readings of the sensors from both blood and dialysate circuits and controlling all the alarm circuits, pumps and valves. The WAK is characterized by a focus processing, so that the Arduino control the safety of the patient by activating an audible alarm using a buzzer or light alarm using LED's if any problem occurred in the system during hemodialysis procedure. All the readings will be displayed on LCD. The block diagram of the WAK including all components and subcircuits is shown in Figure 1.

III. DESIGN

The WAK is divided into subcircuits each, circuit performs a specific task. There are DC motor circuits, Blood and dialysate pump, pressure circuit, temperature circuit, blood leak detection circuit, and air bubble detection circuit [12]. All sub circuits connected to the Arduino microcontroller.

The system contains three DC motors as follow:

- 1) DC motor for Blood pump.
- 2) DC motor for Dialysate pump.
- 3) DC motor for Ultrafiltration pump.

These pumps are used for ultrafiltration process, blood and dialysate circulation. Chopper circuit is used to provide a constant DC voltage to the motors. A 200Hz is selected in order to make a continuous fluid flow.

With the motor voltage V_o , according to

$$V_o = \frac{V_s \times \omega}{\omega_{max}} \tag{1}$$

and the total time period T

$$T = \frac{1}{f} \tag{2}$$

the on time t_{on} can be described as

$$t_{on} = \frac{V_o \times T}{V_s} \tag{3}$$

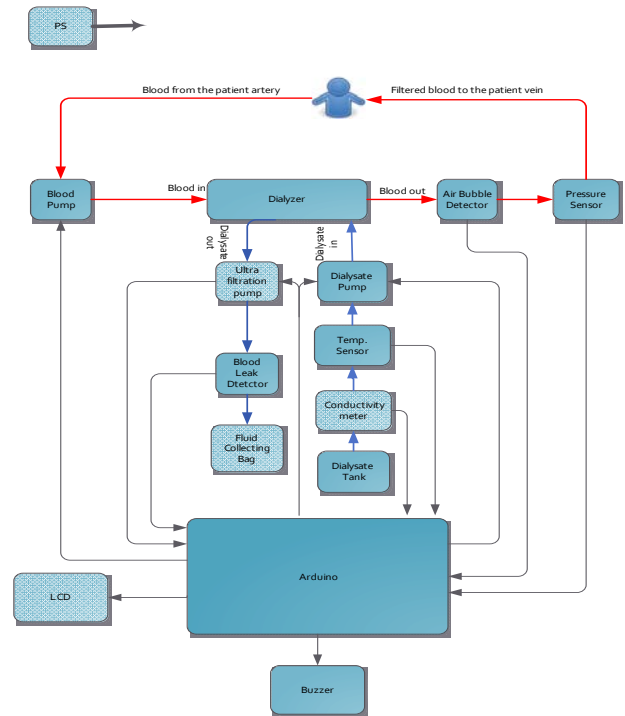

Fig. 1 General Block Diagram

Where f is the chopper frequency, V_s is the supply voltage, ω is the motor speed and ω_{max} is the rated speed of the motor [12].

According to frequency modulation control, the duty cycle (D) is obtained as

$$D = t_{on} / T \tag{4}$$

where the frequency remains constant and on time (t_{on}) is varied.

The pump and motor speed can be calculated as follows [6,12]:

$$Q = A \cdot v \tag{5}$$

$$A = \pi \cdot r^2 \tag{6}$$

$$\omega = \frac{v}{R} \tag{7}$$

Where: Q – flow rate of the fluid in mL/min.

A – cross section area to out flow tube of pump in m^2

v – velocity of blood in m/min

r – radius of out tube in m

R– radius of pump in m

A. Blood Pump

Due to the used available needle size and cannulation type a 300ml/min constant blood flow rate will be used. The internal diameter of the blood tube is 8mm. By substituting the parameters in the equations (1-3):

$$A = 0.502cm^2$$

$$v = 5.96m/min$$

$$\omega = 124.16rpm.$$

B. Dialysate Pump

Using constant dialysate flow rate equal to 500ml/min, and dialysate tube with internal diameter =8.0mm, by substituting the parameters in the equations (1-3):

$$A = 0.502cm^2$$

$$v = 9.96m/min$$

$$\omega = 398.4rpm$$

C. Conductivity Measurement Circuit

Largea three-pole conductivity cell will be used for conductivity measurement, this cell needs an AC current for proper operation, so Wien bridge oscillator used to provide sinusoidal signal with output voltage of 10Vp-p and frequency equal to $f=7.2$ Hz. Figure 2 shows the conductivity measurement circuit.

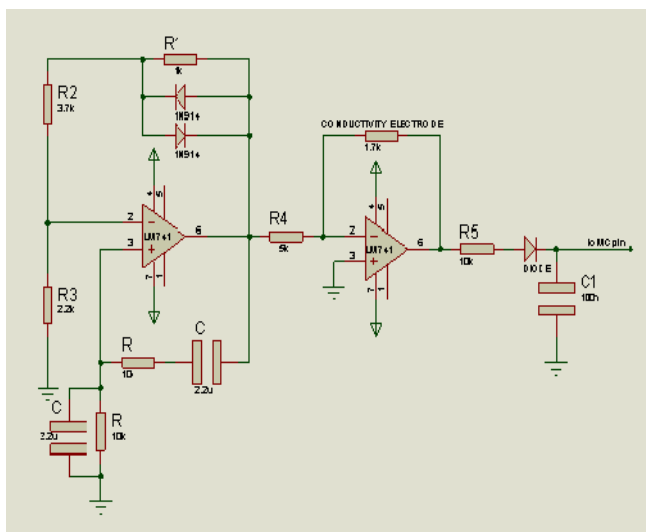

Fig. 2 The conductivity measurement circuit

Wien bridge is able to oscillate only if the gain of negative feedback $A \geq 3$, so R1, R2 and R3 of Wien bridge chosen to achieve this condition: $A = 3.1$.

Figure 3 shows the output voltage from Wien Bridge circuit and conductivity circuit assuming $R_{cond} = 1.7k\Omega$.

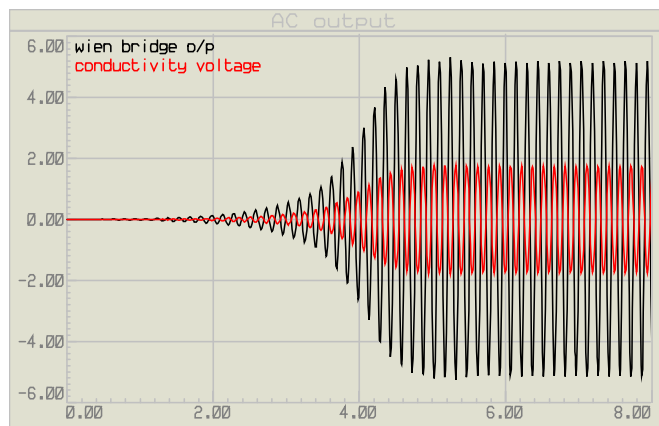

Fig. 3 Conductivity Circuit Output Voltage

In order to read the analog signal by the Arduinomicrocontroller, a half wave rectifier and smoothing capacitor are used to convert the AC signal into DC signal, the output voltage will be:

$$V_{out} = \left(\frac{R_{cond}}{R_4}\right) V_{WB} - V_D \tag{8}$$

Where:

V_{WB} : output voltage of Wien-Bridge

V_D : biased diode voltage

Figure 4 shows half wave rectification and smoothing the signal assuming $R_{cond} = 1.7k\Omega$.

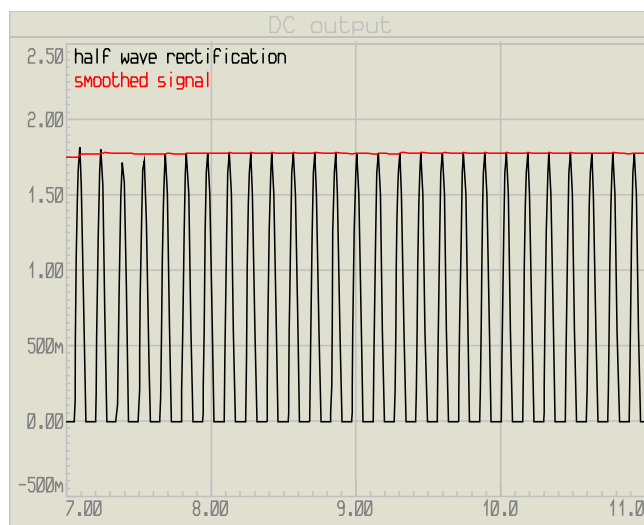

Fig. 4 Smoothed Output Signal

The conductivity in mS/cm will be calculated by:

$$G = 1/R_{cond} \tag{9}$$

$$C = G.k \tag{10}$$

Where: R_{cond} –Dialysate resistivity,

k –cell constant (cm^{-1}) =24 cm^{-1} ,

G –conductance (S),

C –conductivity (mS/cm).

D. Temperature Measurement Circuit

In haemodialysis machines, the measurements of temperature in both circuits, blood and dialysate is important.

A temperature sensor LM35 is used for temperature measurements, which has a very high sensitivity(10mV per 1Cellisouse). Its performance can be affected adversely by intense electromagnetic waves in the system which generated fromrelays, radio transmitters, motors with arcing brushes, SCR transients, etc. To eliminate the noise and to achieve accurate result, a bypass capacitor is connected with a series R-C damper as shown in Figure 5.

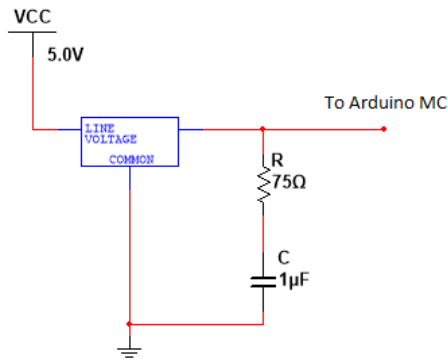

Fig. 5 Temperature Measurement Circuit

E. Pressure Measurement Circuit

After cleaning the blood, it should be return back to the body through the vein with specific pressure valve, the Pressure monitoring is important to ensure that the blood entering with that pressure value.

A pressure sensor SCX15DNC is used for blood pressure measurement as shown in Figure 6, which provides a linear relationship between input pressure and output voltage. The sensor has a span of 90 mV.

A low-pass filter is implemented with $f_c = 15.9H_z$ in order to attenuate any noise signal may be connected to the pressure signal.

The measured pressure it should be amplified with total gain equal to: $2 \left(1 + \frac{R}{R1}\right)$ to make it suitable for display.

While V_{min} produced at minimum pressure where $P_{min} = 0$ and $R1$ used for calibration V_{max} at maximum pressure. The measured pressure can be determined using this equation:

$$P = (V_{out} - V_{min}) \times \frac{P_{max}}{V_{max} - V_{min}} \tag{11}$$

Where: V_{out} – the output voltage
 V_{min} – minimum output voltage at $P_{min}=0$
 V_{max} – maximum output voltage at P_{max} .

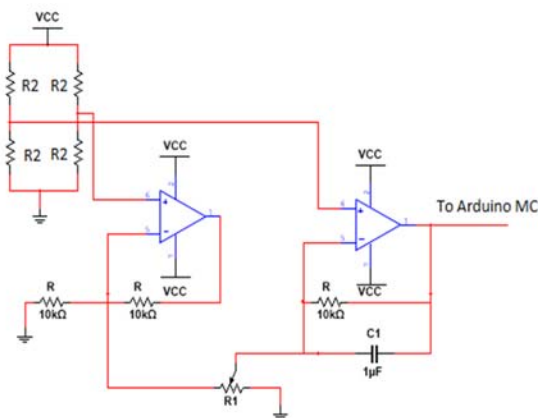

Fig. 6 Pressure Measurement Circuit

Also, additional stages are designed for processing the output signal from the sensors, such as: amplification, de-

amplification, rectification, and filtration. The artificial kidney is equipped with an audible and visible alarm system warns the patient if there are any problems occur during the system performance.

The artificial wearable kidney is designed to match the user important requirements such as light weight, the simplicity of use. All of these options will favor the whole system.

IV. WAK FLOW CHART

The flowchart of the hemodialysis process is clarified as shown in Figure 7. The procedure begins with pressing the start button, so that the WAK rinses the dialysate circuit, which takes about two minutes.

It's worthy to mention that the blood circuit includes a disposable set to avoid viral infection. After that, the patient press “continuous button”, then he enters the target weight (W_T) to be removed in kg. The duration of the procedure is depending on the target weight. Next, the dialysate procedure started automatically until the setting time is over. Finally, before the WAK switched off the system rinses again.

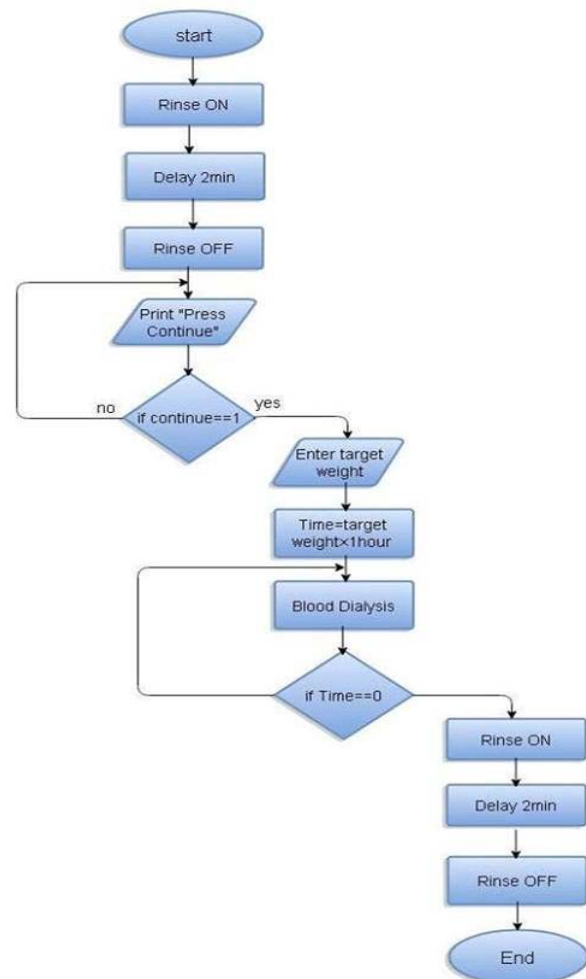

Fig. 7 System Flow Chart

V. RESULTS AND CONCLUSION

The designed wearable artificial kidney prototype for home dialysis shown in Figure 8 was implemented and tested using a chemical solution containing salt and minerals with high concentration (high conductivity). The solution was pumped to the blood circuit and passing through the dialyzer for cleaning.

Experimental results show that a significant drop in the concentration of the chemical solution (salt and minerals) was occurred (low conductivity). In addition to that the level of the solution was dropped also. This mean that the system removes toxic substances and waste products (including salts and minerals) in addition to excess fluids through the semipermeable membrane of the dialyzer, which simulates the mechanism of the natural kidney.

On the other side, all the pumps, sensors and control circuitries are tested to prove the efficiency and the accuracy of the control system during the artificial kidney performance.

The system is divided into three parts: patient "blood" circuit, dialysate circuit, and the controlling and synchronizing circuit. The peristaltic pump is very important to be used because it is able to handle slurries, viscous, shear-sensitive and aggressive fluids, like blood, but the available one which is need 65volt to be changed to another DC motor requires 12volt only.



Fig. 8 Wearable Artificial Kidney Prototype

VI. RECOMENDATIONS

The project can be improved by the following:

1. Use touch screen for display and entering the target weight to lose.
2. Weight reduction as much as possible.

ACKNOWLEDGMENT

This research was supported by the Deanship of Scientific Research at Palestine Polytechnic University. Authors thank

HayaSalhab, Raghda Jabari and Anwar Abu Khreiba for their assistance and contribution during the implementation and testing of the system in the laboratory.

REFERENCES

- [1] Vander AJ, Sherman JH, Luciano DS (eds) " Human Physiology", 6th edition McGraw-Hill inc, USA, 1994.
- [2] Dr Per Grinsted , "Kidney failure (renal failure with uremia, or azotaemia)", UK, 2005.
- [3] Amgen Inc, "10 Symptoms of Kidney Disease", USA, 2009.
- [4] Alfred HJ, Graff LG, Cohen AJ, Shuster A. Treatment of Renal Failure. In: Rose BD, editor. Pathophysiology of renal disease. New York: McGraw-Hill; 1981. pp. 475–575.
- [5] Alonso A, Lau J, Jaber BL. Biocompatible hemodialysis membranes for acute renal failure. Cochrane Database of Systematic Reviews. 2008;(1) Art. No.: CD005283. DOI:10.1002/14651858.CD005283.pub2.
- [6] Twardowski ZJ. Dialyzer Reuse-Part II: Advantages and Disadvantages. Semin Dial. 2006;19:217–226.
- [7] Monchi M, Berghmans D, Ledoux D, Canivet JL, Dubois B, Damas P. Citrate vs. heparin for anticoagulation in continuous hemofiltration: A prospective randomized study. Int Care Med. 2004;30:260–265.
- [8] "Understanding blood pressure readings". American Heart Association. 11 January 2011. Retrieved 30 March 2011.
- [9] Mayo Clinic staff (2009-05-23). "Low blood pressure (hypotension) – Causes". MayoClinic.com. Mayo Foundation for Medical Education and Research. Retrieved 2010-10-19.
- [10] "Guideline for the diagnosis and management of hypertension in adults"(PDF). Heart Foundation. 2016. p. 12. Retrieved 12 January 2017.
- [11] Gambro Lundia AB SD, " The Conductivity of Dialysis Fluid", Lund, Sweden, 2012.
- [12] Qawasma, R., Daud, A.K., "Left Ventricular Heart Assist Device using MC and ECG Feedback", International Journal of Biosensors & Bioelectronics, Volume 3 Issue 3 – 2017.