

Feed back linearised control based three Phase shunt active power filter

ISMAIL Ghadbane and MOHAMED TOUFIK Benchouia

Abstract – This paper presents a simulation study of Feedback linearised Controller of the DC bus voltage and currents of three phase shunt Active Power Filter (APF). The Feedback controller is introduced to improve tracking performance characteristics, power quality and minimized consumption of the reactive power. The algorithm used to identify the reference currents is based on the Self Tuning Filter (STF) for application of The method of instantaneous active and reactive power

Keywords – Harmonics, shunt active filter, Feedback linearised , total harmonic distortion

I. INTRODUCTION

Power electronics devices have been widely used in recent years; while they are convenient in use they cause several power pollutions just like electrical harmonics and low power factor. In high power systems, most electrical devices use three-phase symmetrical power system. But in medium and small power system, single-phase electronic equipments are widely used in domestic, educational and commercial appliances, such as computers, communication equipments and electronic lighting ballasts, etc. These equipments normally have a diode rectifier to convert ac electricity to dc and filter by a huge capacitor.. These equipments behave like nonlinear loads, generating harmonics and cause electromagnetic compatibility problems. For the devices with an alternative input such as: rectifiers, Ac voltage controllers, indirect frequency converters..., the wave shape of the absorptive current of the network is non-sinusoidal. In addition to the fundamental component, this waveform presents harmonic contents which are, in certain cases, very important. These harmonics are propagated from the load towards the network and generate harmonic voltage drops which are added to the fundamental component of the voltage delivered by the network. The result is a form of affected wave, which contains also of harmonic contents; this affected wave can, as mentioned before, cause serious problems of electromagnetic compatibility. Many solutions have been studied in the literature to mitigate the harmonic problems,

such as filtering (passive, active, and hybrid) with various topologies (shunt, series or both) [6] Industrial and domestic equipments actually use a large variety of power electronic circuits such as switch mode power converters, adjustable speed drives, rectifiers and dimmers. These ones lead to significant energy savings and productivity benefits. But unfortunately, they also present non-linear impedance to the supply network and destroying equipments and disturbances of communication equipments and precision instruments [1]. So, it is necessary to develop techniques to reduce all the harmonics as it is recommended in the IEEE 519-1992. The first approach consists in the design of LC filters. But, passive filters are not well adapted as they do not take into account the time variation of the loads and the network [1], [2]. They can also lead to resonance phenomena. The active power filter (APF) can solve the problems of harmonic and reactive power simultaneously. The theories and applications of active power filters have become more popular and have attracted great attention since two decades ago. Since its introduction some twenty years ago, the Active Power Filter APF presents a good solution for disturbance treatment, particularly for harmonic currents and/or voltages. APF is an up-to-date solution to power quality problems. The shunt APF allows the compensation of current harmonics and unbalance, together with the power factor correction, and can be a much better solution than the conventional approach (capacitors and passive filters)

The performance of the APF is determined by the kind of control used. It is more emphasized when the voltages of electrical network contain harmonics and/or are unbalanced. Moreover, the Self Tuning Filter STF is proposed for extracting harmonic currents instead of classical harmonics extraction based on High Pass or Low Pass Filters [4], [5]. The three phase currents/voltages are detected using current/voltage sensors. The inverter currents are controlled by using hysteresis comparators,. The hysteresis control is characterized by its simplicity and its intrinsic speed.. [1][3][7]

II. SHUNT ACTIVE FILTER STRUCTURE

Fig.1 presents the schematic diagram of the three- phase active power filter and the associated control strategy for harmonic mitigation

The power part is composed of an inverter, a filter of coupling R_f L_f and a capacitive element used as source of energy for APF. This element must provide a voltage of quasi-constant value. The fluctuation of this voltage must be weak. The other part is used for commutation control of the Semiconductor elements of the inverter in power part. By

This work was supported in part by LGEB laboratory, Research center, university of Biskra , 7000 Algeria.

I.Ghadbane us with LGEB laboratory, Research center, university of BISKRA , 7000 Algeria. (E-mail:ghismail1984@yahoo.fr).

MT. Bechouia, is with LGEB laboratory, Research center, university of BISKRA , 7000 Algeria. (E-mail:m.t.banchouia@yahoo.fr).

means of control strategies well adapted, it is possible to generate harmonic signals in the output of the inverter, which are used to compensate those present in the distribution network.

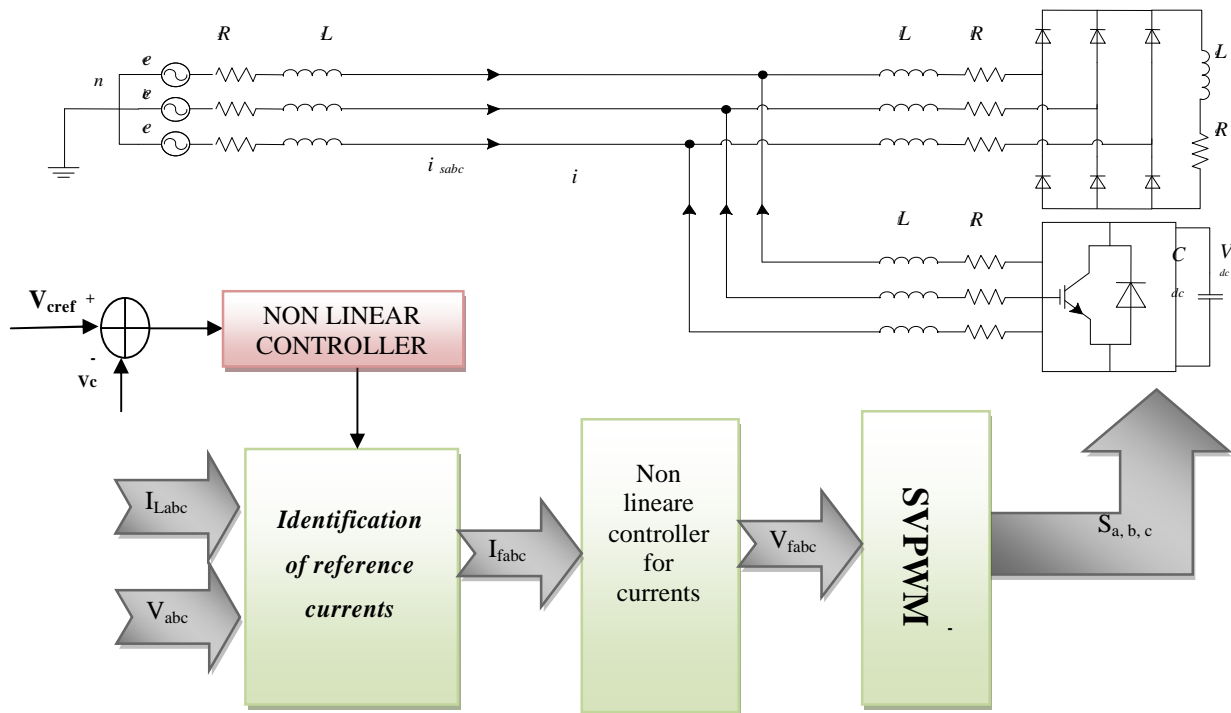

Fig.1 -Network and shunt active filter presentation

III-HARMONIC ISOLATION

Akagi [1] proposed a theory based on instantaneous values in three-phase power systems with or without neutral wire, and is valid for steady-state or transitory operations, as well as for generic voltage and current waveforms called as Instantaneous Power Theory or Active- Reactive (p-q) theory which consists of an algebraic transformation (Clarke transformation) of the three-phase voltages in the a-b-c coordinates to the α - β coordinates, followed by the calculation of the p-q theory instantaneous power components by eliminating the DC component of the instantaneous active power (corresponding to the fundamental component of load current) using a selective Filter STF, so the harmonic components can be identified. Figure 3 shows the modified scheme for the identification of reference currents during simultaneous compensation of harmonic currents and reactive power using the method of instantaneous power by using STF

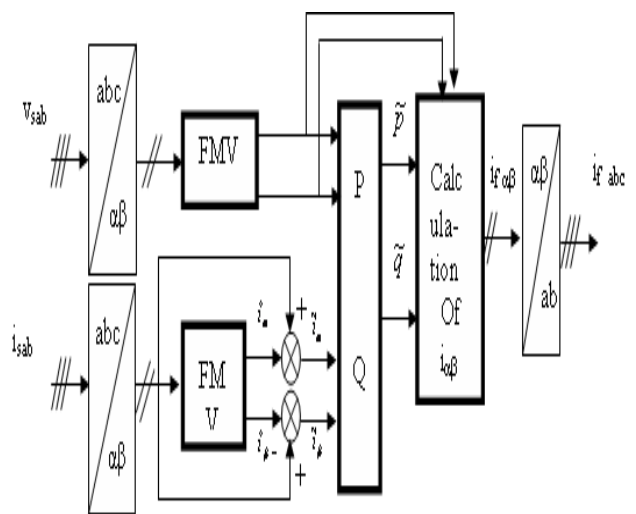

Fig. 2: The method of instantaneous active and reactive power

This method is based on measuring the instantaneous three-phase variables present on the grid with or without zero-sequence components. This method is valid both in steady-state phase. In this control algorithm (Figure 2), measurements of voltages and currents expressed as a three phase (abc) are converted to two-phase system (α - β) is equivalent to using the transform from Concordia leaving the power invariant:

$$\begin{bmatrix} v_a \\ v_b \end{bmatrix} = \frac{\sqrt{2}}{\sqrt{3}} \begin{bmatrix} 1 & -1/2 & -1/2 \\ 0 & \sqrt{3}/2 & -\sqrt{3}/2 \end{bmatrix} \begin{bmatrix} v_{sa} \\ v_{sb} \\ v_{sc} \end{bmatrix} \quad (1)$$

$$\begin{bmatrix} i_a \\ i_b \end{bmatrix} = \frac{\sqrt{2}}{\sqrt{3}} \begin{bmatrix} 1 & -1/2 & -1/2 \\ 0 & \sqrt{3}/2 & -\sqrt{3}/2 \end{bmatrix} \begin{bmatrix} i_{La} \\ i_{Lb} \\ i_{LC} \end{bmatrix} \quad (2)$$

In the presence of harmonics, the power is composed of three parts: active (P), reactive (Q) and deformed (D) as shown by the following equation:

$$S = \sqrt{P^2 + Q^2 + D^2} \quad (3)$$

The instantaneous active power, denoted P (t) is defined by the following equation:

$$P(t) = v_{sa} i_{sa} + v_{sb} i_{sb} + v_{sc} i_{sc} \quad (4)$$

Can be written in the stationary reference:

$$P(t) = v_{sa} i_{sa} + v_{sb} i_{sb} \quad (5)$$

Similarly the instantaneous imaginary power can be written as follows:

$$q(t) = -\frac{1}{\sqrt{3}} [(v_{sa} - v_{sb})i_{sc} + (v_{sb} - v_{sc})i_{sa} + (v_{sc} - v_{sa})i_{sb}] = v_{sa}i_{sb} - v_{sb}i_{sa} \quad (6)$$

Q power a broader meaning than the usual reactive power. In fact, Unlike the reactive power, which considers only the fundamental frequency, the imaginary power takes into account all the harmonic components of current and voltage is why it is given a different name (imaginary power) as a unit with the volt-ampere imaginary (VAI).

The part of the relations (5) and (6), we can establish the following matrix:

$$\begin{bmatrix} p \\ q \end{bmatrix} = \begin{bmatrix} v_{sa} & v_{sb} \\ -v_{sb} & v_{sa} \end{bmatrix} \begin{bmatrix} i_a \\ i_b \end{bmatrix} \quad (7)$$

In the general case, each of the powers p and q has a continuous part and part alternative, which allows us to write the following expression

$$\begin{cases} P = \bar{P} + \tilde{P} \\ q = \bar{q} + \tilde{q} \end{cases} \quad (8)$$

with: \bar{P} Continuous power related to the fundamental component of active power and voltage, \bar{q} Continuous power related to the fundamental component of reactive current and tension, \tilde{p} and \tilde{q} Powers of alternatives related to the sum of the components of disruptive current and voltage. By inverting the relation (7), we can recalculate the currents in the coordinate $\alpha \beta$ as shown in Equation

$$\begin{bmatrix} i_a \\ i_b \end{bmatrix} = \frac{1}{v_{sa}^2 + v_{sb}^2} \begin{bmatrix} v_{sa} & -v_{sb} \\ v_{sb} & v_{sa} \end{bmatrix} \begin{bmatrix} p \\ q \end{bmatrix} \quad (9)$$

Considering equations (8) and (9), we can separate the current benchmark in the three components, active and reactive at the fundamental frequency and harmonics. This leads to:

Finally, it is easy to obtain the reference currents along the axes abc by the inverse transformation of Concordia

$$\begin{bmatrix} i_a^* \\ i_b^* \end{bmatrix} = \frac{1}{v_a^2 + v_b^2} \begin{bmatrix} v_a & -v_b \\ v_b & v_a \end{bmatrix} \begin{bmatrix} \tilde{P} \\ \tilde{q} \end{bmatrix} \quad (10)$$

$$\begin{bmatrix} i_a^* \\ i_b^* \\ i_c^* \end{bmatrix} = \frac{1}{\sqrt{3}} \begin{bmatrix} 1 & 0 \\ -1 & \sqrt{3} \\ 1 & -\sqrt{3} \end{bmatrix} \begin{bmatrix} i_a^* \\ i_b^* \end{bmatrix} \quad (11)$$

The self tuning filter is the most important part of this control which allows to make insensible the PLL to the disturbances and filtering correctly the currents in α - β axis. Hong-scok Song [6] had presented in his PhD work how recovered the equivalent transfer function of the integration expressed by The block diagram of the STF tuned at the pulsation ω_c is shown in the figure 5. The transfer function of this filter is:

$$H(s) = \frac{\hat{i}_{ab}(s)}{i_{ab}(s)} = K \frac{(s+K) + jW_c}{(s+K)^2 + W_c^2} \quad (12)$$

According to the α - β axes, the expressions linking the components FMV output to input $\alpha\beta$ components are:

$$\hat{x}_a = \left(\frac{K}{s} [x_a(s) - \hat{x}_a(s)] - \frac{W_c}{s} \hat{x}_b(s) \right) \quad (13)$$

$$\hat{x}_b = \left(\frac{K}{s} [x_b(s) - \hat{x}_b(s)] - \frac{W_c}{s} \hat{x}_a(s) \right)$$

We obtain the following block diagram for STF

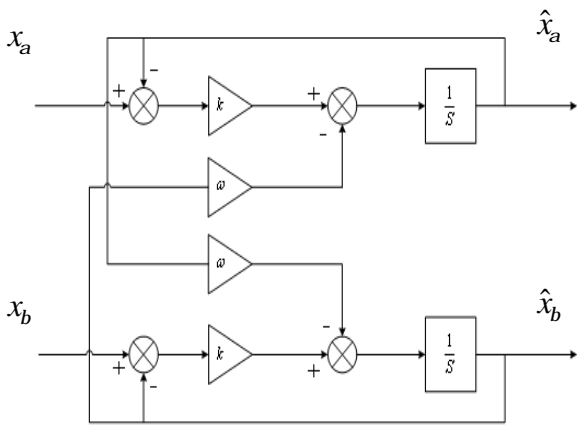

Fig 3. Self Tuning Filter

IV . NON-LINEAR CONTROLLER SYNTHESIS

The dynamic equations of the active filter in the stationary reference are given by:

$$\begin{cases} \frac{dV_{dc}}{dt} = \frac{P_{dc}^*}{C_{dc} V_{dc}} \\ \frac{di_{fa}}{dt} = -\frac{R_f}{L_f} i_{fa} + \frac{V_{fa} - V_{sa}}{L_f} \\ \frac{di_{fb}}{dt} = -\frac{R_f}{L_f} i_{fb} + \frac{V_{fb} - V_{sb}}{L_f} \end{cases} \quad (14)$$

In this control strategy, we have three outputs to regulate.

A- subsystem 1

The equation describing this subsystem is : $\frac{dV_{dc}}{dt} = \frac{P_{dc}^*}{C_{dc} V_{dc}}$

The first sub-system of order 1, is characterized by its state ,

$x = V_{dc}$ and its control : $u = P_{dc}$ We can write the equation as follows:

$$\dot{x} = f(x) + g(x)u \quad (16)$$

$$f(x) = 0 \quad \text{and} \quad g(x) = \frac{1}{C_{dc} V_{dc}}$$

B-Subsystem 2:

The equation describing this subsystem is:

$$\begin{cases} \frac{di_{fa}}{dt} = -\frac{R_f}{L_f} i_{fa} + \frac{V_{fa} - V_{sa}}{L_f} \\ \frac{di_{fb}}{dt} = -\frac{R_f}{L_f} i_{fb} + \frac{V_{fb} - V_{sb}}{L_f} \end{cases} \quad (17)$$

The second sub-system of order 2, is characterized by its

vector state $x = [i_{fa} \ i_{fb}]^t$ and vector control is

$$u = [v_{fa}^* \ v_{fb}^*]^t \quad \text{We can write the system of equations (17)}$$

under the form: $\dot{x} = f(x) + g(x)u$ When :

$$f(x) = \begin{bmatrix} f_1(x) \\ f_2(x) \end{bmatrix} = \begin{bmatrix} -\frac{R_f}{L_f} i_{fa} - \frac{1}{L_f} v_{sa} \\ -\frac{R_f}{L_f} i_{fb} - \frac{1}{L_f} v_{sb} \end{bmatrix} \quad \text{and} \quad g(x) = \begin{bmatrix} \frac{1}{L_f} & 0 \\ 0 & \frac{1}{L_f} \end{bmatrix} \quad (18)$$

Now we will apply the state feedback control on models (17) and (18)

C-DC voltage controller synthesis

The voltage regulation V_{dc} is provided by the subsystem1. To achieve this object requires we must choose $y=V_{dc}$ as output, then, we seek its relative degree.

$$y = V_{dc} = h(x)$$

$$\nabla h = \frac{\partial h}{\partial x} = \frac{\partial V_{dc}}{\partial V_{dc}} = 1$$

Its derivative is given by :

$$\dot{y} = \frac{\partial h}{\partial x} \dot{X} = \frac{\partial h}{\partial X} = (f(x) + g(x)u) \quad (20)$$

And as Lie derivatives, we write:

$$\dot{y} = L_f h(X) + L_g h(X)u \quad (21)$$

With :

$$L_f h(X) = 0 \quad , \quad L_g h(X) = \frac{1}{C_{dc} V_{dc}}$$

it follows that:

$$\dot{y} = \frac{1}{C_{dc} V_{dc}} P_{dc}^* \quad (22)$$

the law of order is expressed by :

$$P_{dc}^* = \frac{1}{L_g h(x)} (-L_f h(x) + v) = C_{dc} V_{dc} v \quad (23)$$

$$v = k_v (V_{dc}^* - V_{dc}) + \frac{d}{dt} V_{dc}^* \quad (24)$$

$$v = k_v (V_{dc}^* - V_{dc}) \quad (25)$$

B-Non-linear current regulator

From the second subsystem, we will construct the command that regulates the currents of the active filter.

i_{fa} and i_{fb} these two currents must follow their references
1st Output :

$$y_1 = i_{fa} = h_1(X) \Rightarrow \nabla h_1 = [1 \ 0]$$

Its derivative is:

$$\dot{y}_1 = f_1(x) + \frac{1}{L_f} V_{fa}^* \quad (26)$$

The order V_{fa}^* appears in the expression of the first derived one (23), therefore the relative degree is equal to 1.
2nd Output :

$$y_2 = i_{fb} = h_2(X) \Rightarrow \nabla h_2 = [1 \ 0]$$

Its derivative is:

$$\dot{y}_2 = f_2(x) + \frac{1}{L_f} V_{fb}^* \quad (27)$$

The relative degree of the second output is equal to 1. Therefore, the total degree is equal to 2 the linearization here is then exact. From equations (23) and (24), it comes:

$$\begin{bmatrix} \dot{y}_1 \\ \dot{y}_2 \end{bmatrix}^t = f(x) + g(x)u \quad (28)$$

$$f(x) = \begin{bmatrix} f_1(x) \\ f_2(x) \end{bmatrix} = \begin{bmatrix} -\frac{R_f}{L_f} i_{fa} - \frac{1}{L_f} v_{sa} \\ -\frac{R_f}{L_f} i_{fb} - \frac{1}{L_f} v_{sb} \end{bmatrix} \text{ and } g(x) = \begin{bmatrix} \frac{1}{L_f} & 0 \\ 0 & \frac{1}{L_f} \end{bmatrix} \quad (29)$$

The order obtained from the theory of feed back of state is defined by

$$\begin{bmatrix} V_{fa}^* \\ V_{fb}^* \end{bmatrix} = g^{-1}(x) \left[-f(x) + \begin{bmatrix} V_1 \\ V_2 \end{bmatrix} \right] \quad (30)$$

We find the relation linear following:

$$\begin{bmatrix} \dot{y}_1 \\ \dot{y}_2 \end{bmatrix}^t = [V_1 \ V_2]^t$$

To impose the static mode on the error, the new entries must be designed, to ensure the convergence of the currents towards their instructions, we must take:

$$\begin{cases} V_1 = K_1 (i_{fa}^* - i_{fa}) + \frac{d}{dt} i_{fa}^* \\ V_2 = K_2 (i_{fb}^* - i_{fb}) + \frac{d}{dt} i_{fb}^* \end{cases} \quad (31)$$

Coefficients K_1 and K_2 are selected in such way that the polynomials $S+K_1$ and $S+K_2$ have poles with negative real parts.

VI . Simulation results and discussions

Some simulation results using model in Matlab-Simulink and SimPower System Blockset are presented. The harmonic current and reactive power compensated by APF implemented in three- phase power systems with the utility power supply voltage of 100V and current source three- phase diode-bridge rectifier with R-L loads as the current compensation object. The design specifications and the circuit parameters used in the simulation are parameters are used for simulation: $V_s = 50$ V (rms), $R_s = 0.1 \ \Omega$, $L_s = 0.566$ mH, $R_c = 0.01 \ \Omega$, $L_c = 1$ mH, $R_{d1} = 26.25 \ \Omega$ and $R_{d2} = 17 \ \Omega$, $L_d = 1$ mH, $V_{dr} = 140$ V, $C = 1100 \ \mu\text{F}$, HB (hysteresis band) = 0.1

To study the performance of the APF, first simulation is done on fixed load (R_L & L_L) and the filter is switched on at 0.12s.

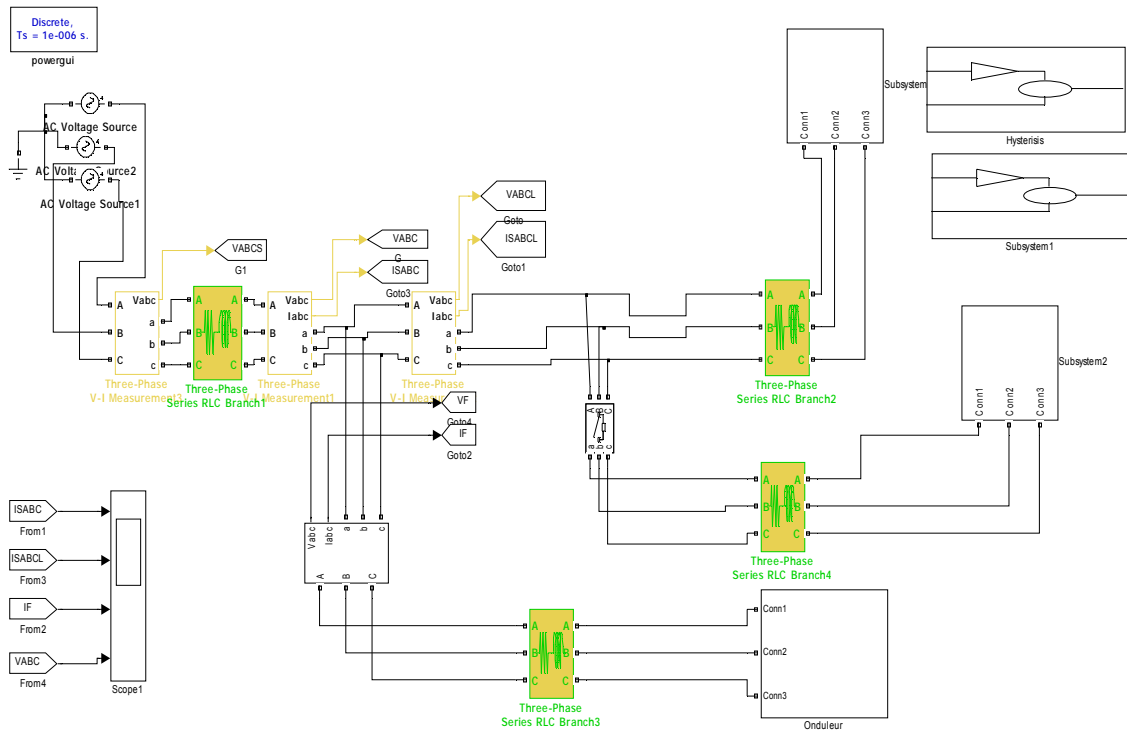
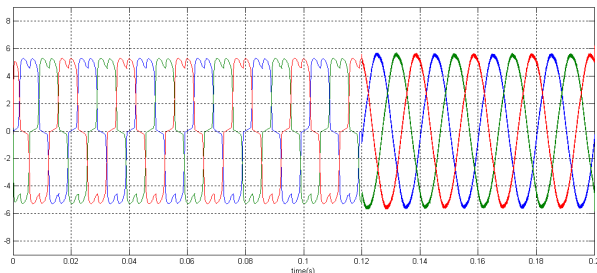
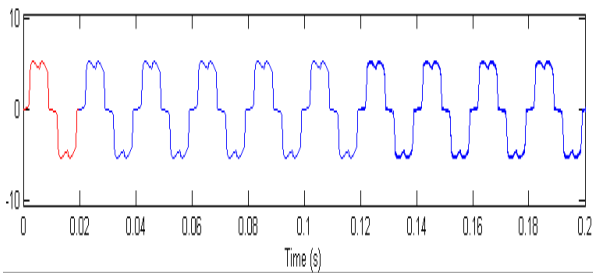

Fig 4. Matlab Simulation Circuit with FEED BACK controller

1
done on fixed load (R_L & L_L) and the filter is switched on at 0.12s.



-a-



-b-

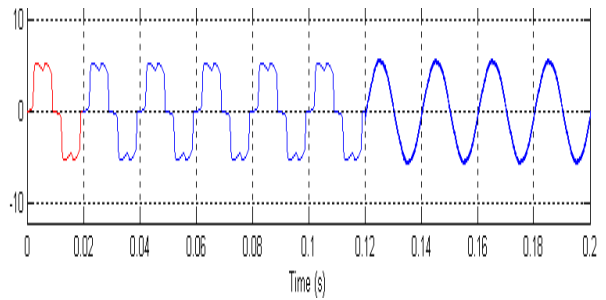

-c-

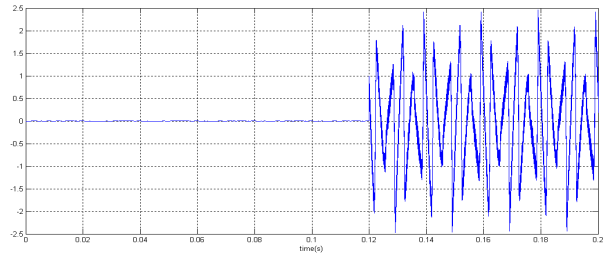

-d-

Fig 4 Three phase main current (b) load current; (c) Mains current; (d) compensating current waveform

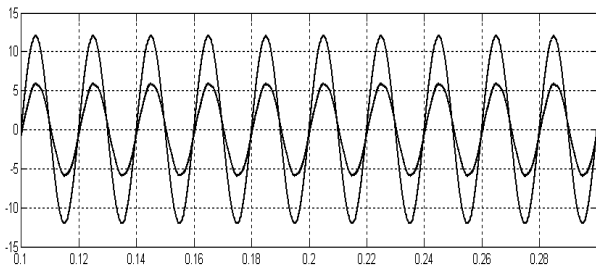

Fig 5. Power factor correction after applying Non linear control APF.

We see that before the connection of the APF, the mains current has a same waveform of the load current. At 0.2s, the APF is connected. mains current will be sinusoidal and exactly in phase with source voltage.

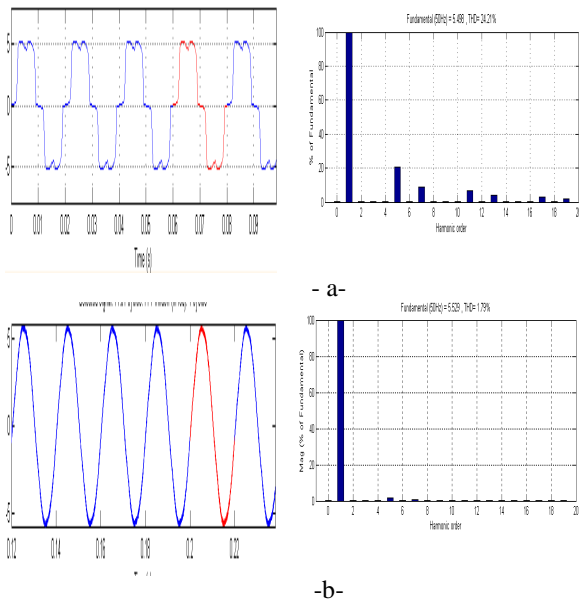

Fig 6 -Mains current waveform and its spectrum, (a) before filtering, (b) after filtering.

Still in Fig.7 a-b; a spectrum analysis shows that I_s current which contained harmonics and a $THD_i = 24.67\%$, will have one spectre at fundamental frequency, all harmonics disappear and the $THD_i = 1.79\%$. To observe the regulating process in NON LINEAR control method in transient condition and the dynamics of the proposed APF, the DC side resistance is changed from R_{d1} to R_{d2} at 0.2s. It is clear from simulation results in Fig.8 that we obtain good transient performance of the source current, DC side capacitor voltage for the non linear controller and the mains current maintains its sinusoidal waveform.

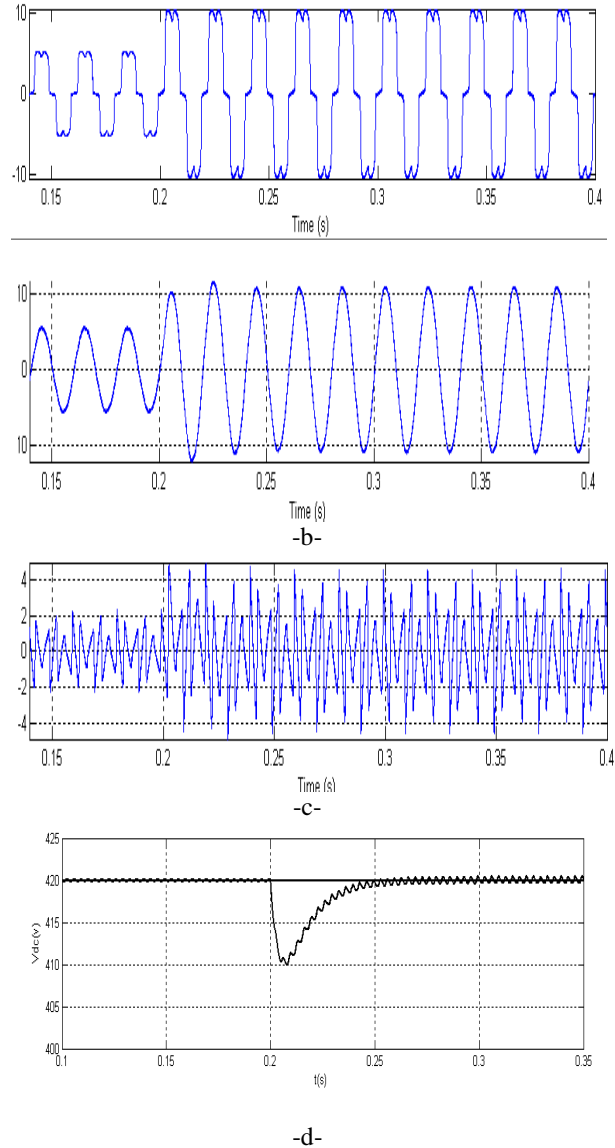

Fig 7 Load perturbation response of non linear controlled shunt APF. (a) load current; (b) Mains current; (c) compensating current waveform (d) dc voltage

A. Influence parameters on the THD:

The performances of the active filter depend on the type of order implemented as well as parameters of the system. In this part, We will study the influence on the THD of the following parameters: inductance of L_f and values of capacitor

B. Variation of the inductance of decoupling

This paragraph illustrates the influence of the inductance of decoupling on the THD of the current of source. For that, we fix the reference voltage standard V_{dc} (420V). The following figure shows that an increase in this inductance generates a reduction in the THD

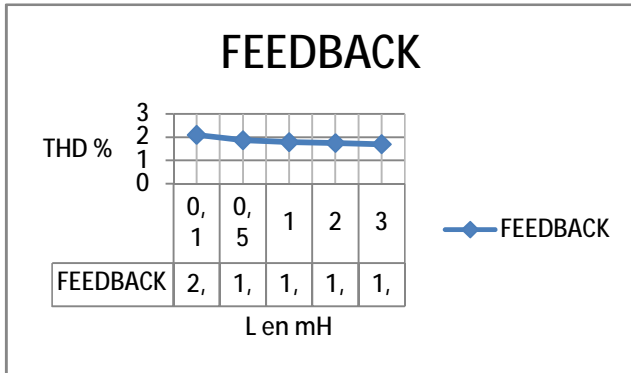
Fig.9. Influence L_f inductance on the THD

C..Variation of value of capacitor:

Figure 10. presents the influence of value of capacitor on the THD of the currents of source. where the THD increase in this variation value of capacitor, generates a reduction in the THD

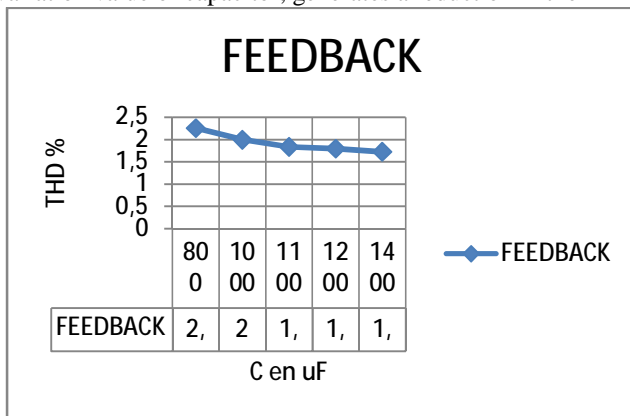

Fig. 10. Influence of C on the THD

VII. Conclusion

In this work, we have shown the effectiveness of the shunt active power filtering especially with the application of NON LINEARE control and with the application of The method of instantaneous active and reactive power The THD of the source current and source voltage after compensation is well below 5%, the harmonics limit imposed by the IEEE-519 standard. Further studies will examine the opportunity of implementing a high frequency output filter with the three-phase inverter. and the power factor was corrected (power supply voltage and current became in phase).

REFERENCES

- [1] S.Beaulieu, M. Ouhrouche " real-time modelling and simulation of an active power filter " IASTED International Conference on Power and Energy Systems PES 2007, Clearwater, Florida, U.S.A.
- [2] Mohamed Abdusalam, Philippe Poure and Shahrokh Saadate "Control of Hybrid Active Filter Without Phase Locked Loop in the Feedback and Feedforward Loops" ISIE, IEEE International Symposium on Industrial Electronics, Cambridge, UK, (2008).
- [3] Soumia Kerrouche, Fateh Krim "Three -phase Active Power Filter Based on Fuzzy Logic Controller "IJ-STA, Volume 3, N° 1, July 2009, pp. 942-955.

- [4] DomenicoCasadi, Gabriele Grandi, UgoReggiani, and Claudio Rossi,"Control methods for active power filters with minimum measurementrequirements," *IEEE APEC*, vol. 2, 1999, pp. 1153-1158.
- [5] S. G. Dan, D. D. Benjamin, R. Magureanu, L. Asiminoaei, R. Teodorescu, and F. Blaabjerg, "Control strategies of active filters in the context of power conditioning," *European Conference on Power Electronics and Applications*, 2005.
- [6] R.R. Joshi, R.A. Gupta and A.K. Wadhvani " adaptive backstepping controller design and implementation for a matrix converter-based im drive system" *Journal of Theoretical and Applied Information Technology* 2007
- [7] K. Hasan, and K. Osman, "Globally Stable Control of Three-Phase Three Wire Shunt Active Power Filters," *Elec. Eng.*, vol. 89, no. 5, 2007, pp. 411-418
- [8] Helder J. Azevedo, José M. Ferreira, António P. Martins, and Adriano S. Carvalho "Direct current control of an active power filter for harmonic elimination, power factor correction and load unbalancing compensation," *Proceedings of the 10th European Conference on Power Electronics and Applications, EPE'03,Toulouse, 2003*, pp. 1-10.
- [9] D. Casadi, U. Reggiani, and G. Grandi, "Active power filters based on a single current measurement system," *System Proceedings Symposium on Power Electronics, Electrical Drives Advanced Machines Power Quality (SPEEDAM'98)*, Italy, June 3-5, 1998.
- [10] K. H. Yiauw, and M. S. Khanniche, "A novel three-phase active power filter," *Rev. Energ. Ren.: Power Engineering*, 2001, pp. 77-84.
- [11] S.Beaulieu, M. Ouhrouche " real-time modelling and simulation of an active power filter" *ASTED International Conference on Power and Energy Systems PES 2007*, Clearwater, Florida, U.S.A.

GHADBANE Ismail

He received his Magister degree in electrical engineering in 2011 from Biskra University.. His research interests are in electrical drives, power electronics, power energy quality and intelligent control systems

BENCHOUIA Mohamed Toufik

He received his Engineer degree in Electrotechnics and Magister degree in electrical engineering from Biskra University in 1991 and 1998 respectively. He received his Ph.D. in electrical engineering from Biskra University in 2006.