

THERMODYNAMIC ANALYSIS OF SOLAR ASSISTED LNG POWER CONVERSION PLANT

Asad Salem¹, Faisal Al-Balooshi²

Abstract - In this study a thermodynamic analysis of a hybrid renewable power generation system is presented. The scope of research is to utilize LNG to increase the overall efficiency of Concentrated Solar Thermal Power generation systems (CSP). A cryogenic Rankine bottoming cycle is incorporated within the CSP power standard vapor Rankine cycle named as topping cycle. A thermodynamic analysis is carried out for the two different models, the first model is the simple cycle from the Concentrated Solar Power technology, and the second model which includes the cryogenic cycle named as combined cycle. The analysis showed the power out of the combined cycle can be increased by 66% of the original power produced by steam cycle, while, the efficiency of the combined cycle can be increased by 45% over the original simple cycle.

Key-Words - Concentrated Solar Power, LNG, Propane Cycle.

I. INTRODUCTION

Renewable energy resources can conceivably provide effective sustainable energy solutions. However, the application of solar energy for power generation purposes is not currently competitive with conventional fossil fuel systems. In current years, there is a growing demand to reduce emissions due to global warming. The energy consumption used for electric power has increased drastically. The use of solar energy is one important contribution for the reduction of fossil fuel consumption and harmful emissions to the environment, while solar cooling for food, beverage, and seafood preservation or air-conditioning is an attractive application of solar energy because both the insolation supply and the need for refrigeration reach maximum levels in the same period. The integration of solar thermal collectors into conventional fossil plants, has proven a viable solution to address the intermittency of power generation and combines the environmental benefits of solar power plants with the efficiency and reliability of fossil power plants.

¹Weisberg Division of Engineering, Marshall University, Huntington, WV USA salema@marshall.edu

²Department of Mechanical Engineering, Rochester Institute of Technology-Dubai, Rochester, NY USA fja2650@rit.edu

The demand for Liquefied Natural Gas (LNG) in power generation is increasing and the trend is expected to further increase in the years to come. The major suppliers of natural gas are concentrated in the Middle East, Russia, and Australia. The transport of NG to major importing destinations like Japan, Europe, USA, etc. would be in the form of LNG. It is here where the solar assisted LNG energy conversion plant (SALTEC) model would come into the picture [1].

The liquefied natural gas, which is mainly Methane-CH₄, is transported from exporting production terminals to the importing terminals by containers, pipelines or in liquid form. Cryogenic tanks are used to transport the liquid form of natural gas. The main benefit of liquefaction of natural gas is the reduction in volume of about 1/600th of natural gas which results in more energy per volume. The burning of natural gas is much cleaner when compared to other fossil fuels [2].

One of the main concerns in the natural gas industry is the regasification of the LNG (Liquefied Natural Gas). The common techniques adapted by the industry have been a challenge to both power generation and receiving terminals of the LNG. The shipped gas is received via either onshore or offshore receiving terminals [3]. There are about 40 existing LNG exporting liquefaction terminals and about 100 existing LNG import or regasification terminals throughout the world. Countries are looking at more efficient ways to generate power and also looking at the best possible fuel it.

CSP is being widely commercialized. There are in excess of 7600 MW of generating capacity worldwide and the growth is expected to continue at a fast base. Concentrated-solar systems use mirrors with tracking systems to focus a large area of sunlight onto a small area. The concentrated solar energy is then used as heat or as a heat source for a conventional power plant. A parabolic trough consists of a linear parabolic reflector that concentrates light onto a receiver positioned along the reflector's focal line. The receiver is a tube positioned directly above the middle of the parabolic mirror and filled with a working fluid.

The goal of this work is to utilize LNG to increase the overall efficiency of Concentrated Solar Thermal Power

generation systems (CSP). In order to achieve this goal, we are proposing to incorporate a cryogenic Rankine bottoming cycle within CSP power standard vapor Rankine cycle named as topping cycle.

The proposed SALTEC model (Figure1) uses concentrating solar thermal power (CSP) technology and has a capacity of 100 MW. The system consists of a parabolic trough, and natural gas (NG) booster, pumps, and a heat exchange, to exchange thermal energy to the topping Rankine cycle. The CSP system uses liquid metal as working fluid. The liquid metal heated to about 500°C and then used to heat steam in a standard turbine generator. The liquid metal is then cooled before it is returned to the receiver tubes. During the availability of solar energy, the energy to heat the liquid metal is mainly solar; natural gas is used during night and when good quality of solar energy is inadequate. In this SALTEC model a cryogenic Rankine bottoming cycle are incorporated in order to enhance the efficiency and increase power generation. The topping cycle which uses concentrated thermal solar energy as an energy source to generate steam is coupled with the bottoming cycle working on the heat rejected from the topping cycle. The bottoming cycle uses propane as the working fluid to utilize the low grade heat energy rejected from the bottoming cycle. The heat rejected from the bottoming cycle is utilized in re-gasifying LNG to NG. This enables the SALTEC system to utilize the cold energy available in LNG as the heat sink.

One of the difficulties in maintaining CSPs is the harsh desert itself; while damaging sandstorms are relatively low, the troughs must be tilted away from wind if it reaches a certain speed. Keeping the troughs clean is essential to the operation of CSP systems. Due to the dusty conditions, about 2% degradation every day in performance is witnessed. Therefore, CSPs need to be cleaned daily. Currently, water is used both to cool the heat transfer fluid and clean the array. For a 100 MW CSP system, it is estimated more than 10,000 gallons of demineralized water are needed each day for cleaning across the whole site.

This proposed setup offers many benefits and advantages over the existing technology. First of all it results in power savings and also helps to cut the cost of maintaining a separate heat sink and air cooling unit for the system. The low temperature evaporated NG can be utilized in many ways to enhance the efficiency of the entire system. For instance, the low temperature NG can be used to cool the ambient air below the dew-point temperature in a dehumidification process to produce demineralized water needed to clean the troughs. It is estimated for a 100 MW system and in weather conditions like Dubai-UAE, around 60,000 liters of demineralized water can be produced daily [4]. The

cool and super dry air which resulted from the dehumidification process can be used to enhance the NG combustion which help to bring down the emissions the system. During operation the turbine-generators produce substantial amounts of heat, and unless it is dissipated, the generators are unable to operate at maximum efficiency. The low temperature super dry air, and the chilled water produced by heat exchange with the low temperature and saturated NG can both used to cool the generator as well as the turbine stator.

Salem and Hudiab [4&5] developed a 20,000 ton/day LNG re-gasification plant that is powered by a renewable energy source and to utilize the synergy of the LNG to enhance the efficiency of power generation systems and to couple the regasification plant with water desalination system. Concentrated solar energy was used to heat ambient air, this heated ambient air is, then, introduced to a humidification process. During this exchange of energy the evaporation of the LNG will take place and the saturated hot air is cooled below the dew point where fresh water is produced as a result of this energy exchange. The evaporated NG will go through additional heating, and then introduced to gas turbines along with cold dry air for combustion.

Salem et.al [6] developed a LNGTEC Power Plant which works by re-gasification LNG and incorporating bottoming cycles to generate power by recapturing the waste heat and utilizing the cold energy available in LNG to be used as a heat sink for the system. In the LNGTEC model, exhaust heat from the topping (Brayton) cycle is absorbed by a high temperature Rankine bottoming cycle which uses steam as the working medium. The waste heat rejected from bottoming Rankine cycle is absorbed by a low temperature Rankine bottoming cycle with propane as the working medium. The heat rejected from this low temperature Rankine cycle is used to re-gasify LNG to NG thus, this unit works as the heat sink for the LNGTEC. The cold energy available in NG after vaporization of LNG is further used to cool ambient air to the inlet of the Gas Turbine (GT) thereby fully utilizing the cold energy that was contained in LNG. The NG required for combustion is provided from this regasification and the excess is stored in a reservoir which can be used as city gas. The LNGTEC power plant is modeled by considering the mass & energy balances. The model is tested under various conditions of temperatures and relative humidity. The results show that there is a substantial increase in the efficiency of the GT which translated to the efficiency of the power plant as a result of cooling the air that is fed to the GT. The LNGTEC attained a maximum efficiency of 63% at 5°C and 60% relative humidity. At ambient air intake the LNGTEC efficiency was found to be 52%. Another observation from the simulations was, as the inlet air temperature to the turbine decreases the air fuel ratio

decreases. Thus, the power plant model together with LNG regasification and air cooling, utilizes most of the heat energy which is rejected from the primary Brayton cycle to convert to useful work which would else be rejected to the atmosphere along with the flue gases which would harm our atmosphere. This LNGTEC model is a mix of various technologies and a proposal for the better utilization of energy to generate power.

Shi & Che [7] evaluated the performance of a combined cycle using low temperature waste heat recovery of LNG. A good performance with net electrical and exergy efficiency for a typical operating condition were achieved. While, Y. Hisazumi [8] proposed a high efficiency power generation system with an LNG vaporizing system.

II. METHODOLOGY

The main purpose of the proposed design is to maximize the output and efficiency of the CSP powered system and minimize any wasted energy. The proposed design covers four main areas, the solar energy loop, steam Rankine cycle, propane Rankine cycle, and the LNG vaporizing unit coupled to the design.

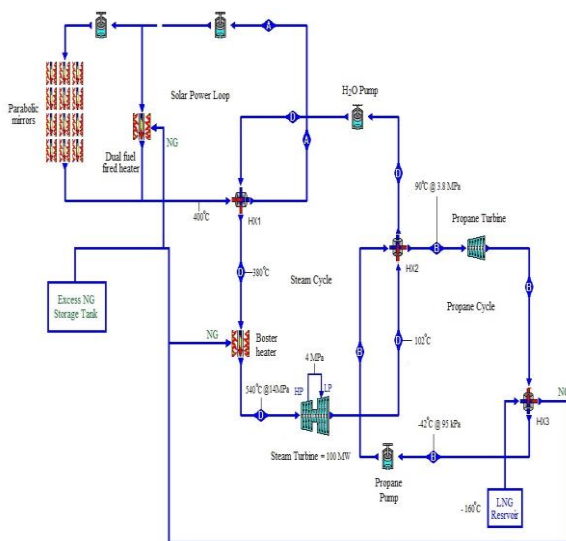

Figure 1: Schematic of proposed SALTEC model with LNG regasification and air cooling

The LNG vaporizing unit is a very vital component in the system as it would facilitate the use of the cold energy available in LNG to be used as a heat sink for the propane cycle. The liquid metals in the concentrated solar power loop is heated using the parabolic mirrors and then it passes through heat exchanger (HX1) where the energy is transferred to the steam topping cycle. The

heated steam is then expanded in the turbine of the steam cycle to produce power.

The spent steam from the turbine is then fed into another heat exchanger (HX2) where energy is transferred from the steam cycle to the propane bottoming cycle and thereby condensing the steam to water and heating up propane.

The heated propane is then expanded in the turbine of the propane cycle to produce energy. The spent propane exiting from the turbine is then fed into another heat exchanger (HX3) where energy is transferred from the spent propane to the LNG. This results in the vaporization of the LNG to NG, and condensation of propane to -160°C liquid form.

The NG is used to power the booster heater continuously, and also it powers the dual fuel fired heater in the back up time (for example, winter season, night time, cloudy days). The need for an expensive and inefficient thermal energy storage system (TES) is eliminated by using NG as an additional and supplementary energy source. It will, also, enables the proposed plant to counteract the unpredictability in system output due to unexpected shifts in the weather, extend the range of operation of the solar based system beyond daylight hours. The power produced throughout the day can be more efficiently harmonised with energy demand, therefore, enhancing the system operational envelope and increasing the value of the power as well as the total beneficial power output of the system at a given maximum turbine capacity.

The proposed model recovers almost all the energy carried away by the concentrated solar power with incorporation of the bottoming cycles. The LNG vaporization unit recovers the cold energy spent in liquefying NG to LNG by working as a condenser for propane cycle.

III. ANALYSIS AND RESULTS

The overall efficiency of a power plant is dependent on the temperature of the heat source (CSP) – efficiency improves with increasing temperature. It, also, depends on the temperature of the heat sink. Therefore, using LNG presents higher potentials for higher overall efficiency of the heat engines based power generation system.

A thermodynamic analysis is carried out using two different models, The first model (option 1) is a CSP system coupled with a simple vapour Rankine cycle, and the second model is the proposed model with waste heat propane recovery cycle combined with the simple cycle as shown in Figure 1 (option II).

Although the heat engine's efficiency increases with higher temperature, the overall efficiency of the CSP System (Figure 2) does not increase steadily with the receiver's temperature. On the contrary, the receiver's efficiency is decreasing, as the amount of energy it cannot absorb grows by the fourth power as a function of temperature. Hence, there is a maximum reachable temperature.

The solar collector efficiency depends on the incidence angle modifier, angle of incidence, ambient temperature and incident radiation of the collector surface. For the CSP solar collectors the efficiency was calculated through:

$$\eta = \epsilon - \frac{(T_{in} - T_{amb})}{I} \quad (1)$$

In this case, the dependence of optical efficiency (ϵ) with incidence angle (i) is expressed by the following:

$$\epsilon = 0.61 + 0.002 i \quad \text{for } 0 \leq i < 35$$

$$\epsilon = 0.628 + 0.009 i \quad \text{for } i \geq 35$$

Simple Cycle:

Overall Efficiency:

$$\eta = \frac{(\dot{W}_{turbine} - \dot{W}_{pump})}{(\dot{Q}_{HX} + \dot{Q}_{SH} + \dot{Q}_{pump})} \quad (2)$$

Another definition of efficiency is also possible:

$$\eta = \frac{(\dot{W}_{turbine})}{(\dot{Q}_{HX} + \dot{Q}_{SH} + \dot{Q}_{pump})} \quad (3)$$

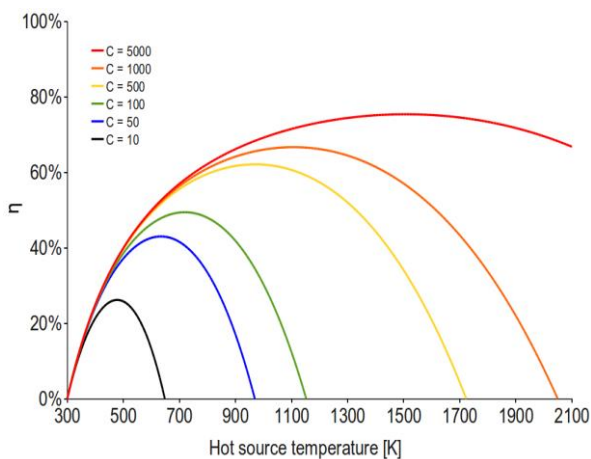

Figure 2: The overall efficiency of the CSP System [9]

The complete proposed combined cycle is shown in figure 1, where the heat energy transferred from solar loop to steam cycle via heat exchanger 1, to propane cycle via heat exchanger 2 and ends up with LNG vaporizing unit which is shown as heat exchanger 3 in the diagram.

$$\eta_{propane \ cycle} = \frac{(\dot{W}_{turbine} - \dot{W}_{pump})}{(\dot{W}_{pump})} \quad (4)$$

Overall combined cycle efficiency:

$$\eta = \frac{(\dot{W}_{steam+propane} - \dot{W}_{psteam+propane})}{(\dot{Q}_{HX} + \dot{Q}_{SH} + \dot{Q}_{pump})} \quad (5)$$

The power generation and efficiencies of both models were found using the above set of equations. The output power of the steam turbine was set at 100 MW due to the selection of the simple power plant (Option1) configuration. The combined cycle power measured as 166 MW, which is an increase of power by 66% of the original power produced by steam cycle as shown in Figure 3. Table 1 summarizes the analysis results for option1 and option II.

The bottoming propane cycle output and efficiency is limited to the heat recovered from the topping steam cycle, and most of the time it will remain approximately the same value as steam leaves the steam turbine in a saturation conditions. The efficiency of the combined cycle increases by 45% of the steam cycle efficiency as shown in Figure 3.

IV. CONCLUSION AND FUTURE WORK

This study compares the proposed SALTEC plant, with a standard or stand-alone CSP plant. In order to make a direct comparison with the SAPG, the solar field for the CSP plant was unaltered.

Annual simulations at a conventional North-South orientation were performed. Parabolic trough collectors are the most mature concentrating solar technology and was used for the simulations. Furthermore, the same power block specifications were used for both plants. From a SALTEC perspective this can be seen as being conservative.

The stand-alone CSP plant is a complete plant, including solar field, power block and balance of plant, while the SALTEC is essentially a solar field integrated into a power plant.

From the analysis carried out in this study, it can be seen that the result of the proposed combined cycle has increased. The bottoming propane cycle together with LNG vaporization unit puts forward an efficient method of recovering the energy in the LNG power production.

The results of the proposed combine cycle design shown in F showed a maximum efficiency of 29% and a power output of 166 MW. It's clear that the rejected heat from the topping steam cycle has enough energy to run a propane cycle with an output power of 66 MW.

- It is noticed that in terms of the conversion of solar thermal energy, SALTEC proved at least 1.6 times more efficient than the CSP system.
- The annual electricity generated from solar thermal at the SALTEC plant is over 60 percent more than from the stand-alone CSP plant.
- The value of hybridizing CSP found SALTEC to be competitive with large scale, standard or stand-alone CSP plants in terms of 'levelled' cost of electricity

Table 1: Thermodynamic Analysis of both Options

		T (°C)	P (kPa)	H (kJ/kg)	Work
Turbine 1	In (SH)	540	14000	3434.2	
	Out		4000		
Turbine 2	In				
	Out (Sat)	102	110	2678.0	
Total					100 MW
Condenser	In (Sat)	102	110	2678.0	
	Out (SC)	48	110	201.06	
Heat Out					385 MW
Heat Exch	In (SC)	48	14000	213.07	
	Out (SH)	380	14000	2918.3	421 MW
Super Heater	In (SH)	380	14000	2918.3	
	Out (SH)	540	14000	3434.2	80 MW
Propane Cycle					
Turbine 1	In	90	3800	337.98	
	Out	30	95	232.5	
Work-T1					66 MW
Condenser	In	30	95	232.5	
	Out	-42	95	-200.43	
Heat Out					321 MW
Heat Exch	In	-42	3800	-181.82	
	Out	90	3800	337.98	385 MW

The LNG vaporizing unit utilizes the maximum possible energy available from the system, In addition it helps in reducing the heat rejected to the environment which has a very adverse effect on the environment. Thus the proposed model has many advantages compared to the conventional setups. It is a more viable solution than the stand alone CSP systems.

The proposed model is a simple design of combined cycles which uses wasted heat as an energy input. More work will be done to enhance the design of the proposed combined cycle to reach commercialization level of production.

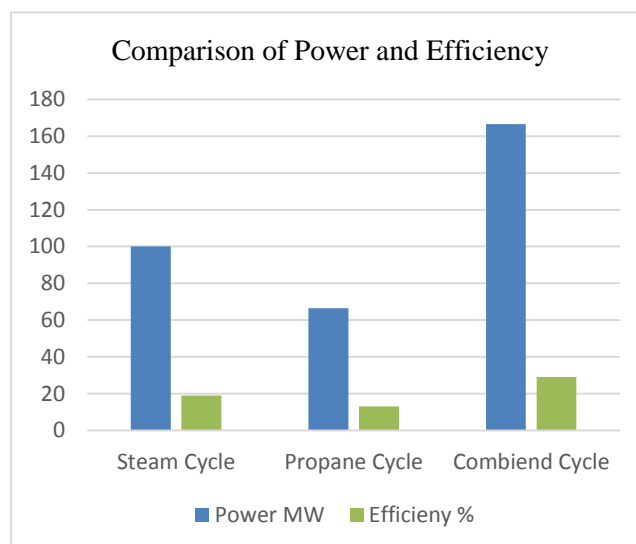

Figure 3: Comparison of Power Output and Efficiency

NOMENCLATURE

HX	Heat Exchanger
η	Efficiency
W	Work
Q	Heat Transfer
CSP	Concentrated Solar Power
NG	Natural Gas
LNG	Liquefied Natural Gas

REFERENCES

- [1] Exxon Mobil, 2012 *The Outlook for Energy: A View to 2040*
- [2] The California Energy Commission, *Liquefied Natural Gas Worldwide*
- [3] Kumar S., Kwon H. T., Choi K. H., Hyun Cho J., Lim W., and Moon I., 2011, *Current status and future projections of LNG demand and supplies: A global perspective*, Energy Policy.
- [4] Salem, A. and E. Hudiab, "LNG Regasification System to Enhance the Performance of Gas Turbines and Water Desalination Systems", *Inter. J. of Energy*, pp. 84-90, Vol. 8, 2014, ISSN: 1998-4316
- [5] Salem, A. and E. Hudiab, "Solar Powered LNG Regasification: Enhancing Power Generation and Water Desalination", *Adv. in Environmental Sciences, Development and Chemistry, Proceedings of the 2014 International Conference on Energy, Environment, Development and Economics (EEDS 2014)* pp. 73-78, 2014 ISBN: 978-1-61804-239-2
- [6] Salem, A.; R. G. Mathews, and A. K. Mathew, "LNG Energy Conversion Power Plant", 3rd International conference on Urban Sustainability, Cultural Sustainability, Green Development, Green Structures And Clean Cars (USCUDAR '12), pp 113-118, ISBN:978-1-61804-132-4
- [7] Shi X., and Che D., 2009, *A combined power cycle utilizing low-temperature waste heat and LNG cold energy*, *Energy conversion and management*, 50(3), pp. 567-575.

- [8] Hisazumi Y., Yamasaki Y., and Sugiyama S., 1998, *Proposal for a high efficiency LNG power-generation system utilizing waste heat from the combined cycle*, Applied Energy, 60(3), pp. 169–182.
- [9] Julio Chaves (2008) *Introduction to Nonimaging Optics*, CRC Press, [ISBN 978-1420054293](https://doi.org/10.1080/002231408024293)
- [10] Jaber Q. M., Jaber J. O., and Khawaldah M. A., 2007, *Assessment of Power Augmentation from Gas Turbine Power Plants Using Different Inlet Air Cooling Systems*, JJMIE, 1(1).
- [11] Rahman M. M., Ibrahim T. K., Kadirgama K., Mamat R., and Bakar R. A., 2011, *Effect of operation conditions and ambient temperature on performance of gas turbine power plant*, Advanced Materials Research, 189, pp. 3007–3013.
- [12] Cengel Y. A. and Boles M. A., 1989, Molar mass, gas constant and critical-point properties. *Thermodynamics and Engineering Approach*, McGraw-Hill.
- [13] Craig E. Tyner, J. Sutherland, and W. R. Gould, "Solar Two: A Molten Salt Solar Power Demonstration", consortium of Sandia National Laboratory, Southern California Edison Company – SCE, and sponsored by DOE, under contract No.DE-AC0494ALd3500.
- [14] A. Favi. OLT Livorno FSRU: an innovative solution for the gas industry. Convegno Tematici ATI-2012 Sesto San Giovanni (MI).
- [15] Salem, A.," Hydrodynamic behavior of a drag-reducing fluid in obstruction flow meters ", WSEAS/IASME International Conference on Fluid Mechanics, published in IASME Transactions, Issue 4, Volume1, October 2004.