

Experiences of pilot operation of the photovoltaic system

F. Hruska

Abstract—The system LABI is extended a experiment DE10 – photovoltaic system. The experiment DE10 offers remote access for students and a professional community studying and testing the photovoltaic specifics without time, financial and other regression. At the moment the system consists a photovoltaic panel of monocrystal semiconductor, a system of measurement and control and a system of remote data transfer via the Internet. During a pilot operation there are confirmed functions and practicing of the system. There were achieved positive experiences.

Keywords— photovoltaic, photovoltaic system, track system, measurement, automatic control.

I. INTRODUCTION

THE laboratory system LABI with remote access [1],[2] was extended the real laboratory experiment DE10 – photovoltaic system [3],[4],[5]. There were utilized all priority and advantages of the system LABI: its openness, extending, remote accessing for students and people of professional community.

The experiment DE10 consists modern and actual photovoltaic system. There are solved the specific problems of photovoltaic: automated tracking of the panel and changing the its position according to position of the sun during the day and year, manual setting of position for studying and testing the global radiation and efficiency of transfer sun irradiation on the electric energy. The using of the system is via the remote access over the Internet and manual processing.

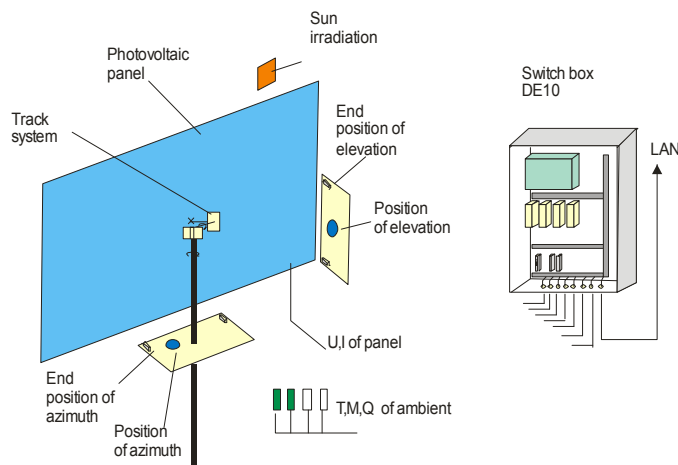

Fig. 1. Scheme of system DE10 – photovoltaic system

The scheme of the all system DE10 is in the fig. 1. The one contents : a track device for two axis, a set of end switches for azimuth and elevation position, potentiometric sensors of position , a sensor of sun irradiation, measurement of voltage and current of photovoltaic panel, sensors of temperature, moisture and other ambient parameters . The input system is connected to switch box. The switch box has located all transmitters, supplies and controlling computer accordant with protection. The main output is connected to the Internet.

The system DE10 is have been opening and testing according to technology and system at the moment. Its installation is on the roof a building of Faculty, see in fig. 2. The switch-box is connected to AC power lines 230V/50 Hz and to the LAN of faculty.



Fig. 2 Photograph of installation of system DE10

II. SPECIFIC POINTS OF SYSTEM STRUCTURE

Over development and projecting of system there were solving some specific points of structure. The first point is track subsystem. Literature search offered information in current solvings in the world. Their analysis gave results with some restriction. Financial problem and application were reason of negative results. There was choice technical clean solving with high accuracy and sensitivity. It was the solving with step motors and big number of steps. The motors are combined with robust gears. The track system has high quality and function parameters. View on track system is in fig. 3.

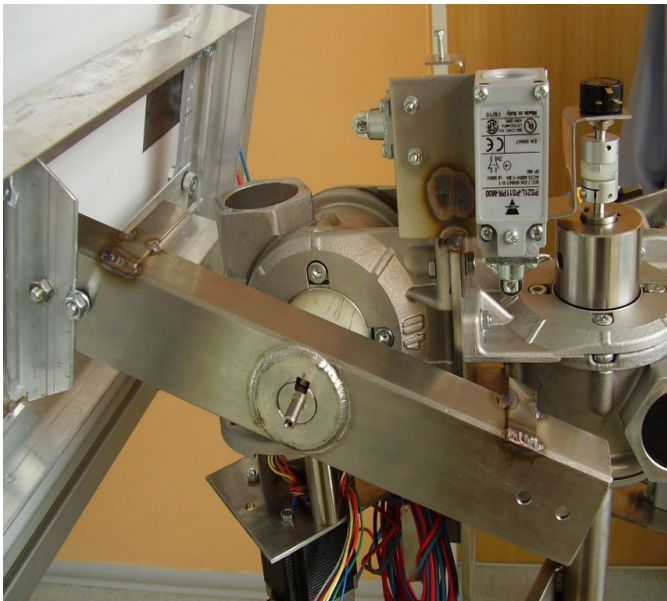

Fig. 3 Photograph of track system DE10

The control and informatics system was projecting with goals of conflict less connection to current system LABI with older experiments and of compatibility between mechanical and electrical system. Main hardware parts are photovoltaic panel, the track system and measurement and control system. A signification part of DE10 is software application. There is used the programmable system Control-WEB. The its application makes: data acquisition, its evaluation, control of panel position according to calculated values of azimuth and elevation, data archiving and remote system communication of type client-server via the Internet.

III. MAIN PARAMETERS

Experiment equipment DE10 contents with parameters:

- Photovoltaic panel,
 - o Type STR 36-55, producing by SOLARTEC CZ,
 - o Nominal/pick to pick power 55W
 - o Nominal voltage 12V, optimal voltage 17,6 V, max. voltage 21,6 V
 - o Short current 3,42A, optimal current 3,13A
 - o Proportion 0,991 m length/ 0,451 m width/0,034 m thickness
 - o Weight 5,5 kg
 - o Technology monocrystalline Si Cover IP 54, resistance against hail storm, frost and snow
 - o Operation temperature from -35°C to +85 °C.
- Track system, 2 pieces of step motors and gears with 20Nm power unit of control impulses, range of azimuth position: 90° až 270°; range of elevation position: 0° (vertical position to surface of earth) až 90° (horizontal position to surface of earth).
- Measuring sensors:
 - o Temperature and moisture of ambient (range - 25 up to 50°C, 10-98% rel. moisture, output 4-20 mA)

- o irradiation (up to 100 kLux, output 4-20 mA),
- o position of azimuth and elevation with potentiometers, range up to 270°, output 0-100 Ω,
- o DC voltage and current from panels, range $U=0-25V$, $I=0-3,5A$.
- Switch box with equipment:
 - o Industrial PC, type DataLab/PC with interface: mouse, keyboard, USB, TCP/IP_RJ45,
 - o Unit of inputs and outputs, type Datalab_I/O
 - o Line power 230VAC
 - o Supply 24V DC

IV. EVALUATION MODEL OF PANEL POSITION

Very important part of control system is mathematical model of track system. It has to evaluate according to current date and time of day the right position of panel.

The algorithm is programmed in the SCADA system, ControlWEB and implemented in central unit the DataLab system (ICP). The system brings the inputs data (date of day DD and of month M from operational system of ICP). As input constant there are declination (SKLON) and azimuth (ADE) of the area of panel in the face to direction of sun radiation.

The results of evaluation are auxiliary data: time evaluation, evaluation of declination, evaluation of angle of sun position, evaluation of angle of irradiation and main control date: evaluation of elevation and azimuth of track system. The central unit IPC then sends the output signal to step motors and the right position of panel is setting up.

Very interested aspect for professional public is the program for testing of calculation the position of panel according to position of sun. In the next table there is showed a program in BASIC language for this testing and for learning the problem sun and position on the Earth. The comment in the program is in Czech language too.

```

Program výpočtů polohy solárního panelu/Evaluating of
solar panel position
[start]

input "Zadání dne datumu/Day of date (DD):"; den
input "Zadání měsíce datumu/entry of month of date
(MM):"; mes
input "Zadání zeměpisné šířky/entry of latitude (°):"; lati
input "Zadání aktuálních hodin /entry of actual o'clock
(hh):"; hod
input "Zadání aktuálních minut /entry of actual minutes
(mm):"; min
input "Odklon kolmé roviny /entry of declination (°):";
sklon
input "Odklon azimutu kolmé roviny /entry of azimuth for
declination (°):"; ade
input "Nadmořská výška /entry of m above sea (°):"; nadvy

'výpočty času/evaluation of time
minutes=ABS(min+(hod)*60-12*60)

```

```

zmenamin=minutes-12960
zmenasek=zmenamin/.01667
zmenast=zmenasek*.004167
zmenarad=zmenast*3.14/180

print minutes
print zmenamin
print zmenasek
print zmenast
print zmenarad

' výpočty declinace/ evaluation of declination
tau=0.98*den+29.7*mes
taurad=tau*3.14/180
declinace=23.45*SIN((tau-109)*3.14/180)
declinacerad=declinace*3.14/180
sinus=SIN((tau-109)*3.14/180)

print tau
print taurad
print declinace
print declinacerad

'výpočty elevace/evaluation of elevation
latirad=lati*3.14/180
casuhel=minutes*0.25
casuhelrad=casuhel*3.14/180

print latirad
print casuhel
print casuhelrad

'výpočty výšky slunce/evaluation of angle of sun position
sinh=SIN(declinacerad)*SIN(latirad)+COS(declinacerad)*
COS(latirad)*COS(casuhelrad)
vyskahrad=ASN(sinh)
vyskah=vyskahrad*180/3.14

print sinh
print vyskahrad
print vyskah

'výpočty azimutu
sina=SIN(casuhelrad)*COS(declinacerad)/COS(vyskahrad)
arad=asn(sina)
astu=arad*180/3.14

print sina
print arad
print astu

'uhel ozáření/evaluation of angle of irradiation
sklonrad=sklon*3.14/180
adif=astu-ade

```

```

adifrad=adif*3.14/180
cosg=SIN(vyskahrad)*cos(sklonrad)+COS(vyskahrad)*SIN
(sklonrad)*COS(adifrad)
grad=acs(cosg)
gstu=grad*180/3.14

print sklonrad
print adif
print adifrad
print cosg
print grad
print gstu

goto [start]

```

Table 1: Source text of BASIC's program

The user of the program enters the input data:

- Entry of day of date (DD):";den
- Entry of month of daten (MM):"; mes
- Entry of latitude (°):"; lati
- Entry of actual o'clock (hh):";hod
- Entry of actual minutes (mm):"; min
- Entry of declination (°):"; sklon
- Entry of azimuth for declination (°):"; ade
- Entry of meters above see (°):"; nadvy

The results of the calculation by the input are in the table 2 for four situation. The red data are input value and there are datum and time for some date for all year.

The test T1 is for 22.December in 12:05 o'clock. The elevation is as a parameter **vyskah** =16,592° and azimuth is as a parameter **astu**= 1,2°.

The test T2 is for 22.October in 10:00 o'clock. The elevation is as a parameter **vyskah** =23.141° and azimuth is as a parameter **astu**= 32,19°.

The test T3 is for 21.March in 15:00 o'clock. The elevation is as a parameter **vyskah** =27.313° and azimuth is as a parameter **astu**= 52,72°.

The test T4 is for 21.June in 12:00 o'clock. The elevation is as a parameter **vyskah** =63,495° and azimuth is as a parameter **astu**= 0,0°.

The data of results were using and could use during the testing of the system.

The scheme of all control system of tracking is in fig. 4. The algorithm of calculation of panel position has output to two step motors, The one showed as V is to change of elevation direction, other as the motor H is to control of azimuth position. The both motors are controlled by impulse signals from units DO3.

Input signals for this algorithm are for contact sensors from end position: east direction of azimuth, west direction of azimuth, down direction of elevation and up direction of elevation. The all inputs come to unit AD1.

	T1	T2	T3	T4
DD	22	22	21	21
MM	12	10	3	6
lati	50	50	50	50
hod	12	10	15	12
min	5	0	0	0
sklon	0	5	0	0
ade	0	5	0	0
nady	20	200	200	200
minutes	5	120	180	0
zmenamin	-12955	-12840	-12780	-12960
zmenasek	-777145	-770246	-766646	-777444
zmenast	-3238,3	-3209,6	-3194,6	-3239,6
zmenarad	-56,49	-55,98	-55,72	-56,51
tau	377,96	318,56	109,68	198,78
taurad	6,593	5,557	1,913	3,4676
declinace	-23,445	-11,53	0,278	23,449
declinacerad	-0,40899	-0,20114	0,004852	0,40906
latirad	0,8722	0,8722	0,8722	0,8722
casuhel	1,25	30	45	0
casuhelrad	0,0218	0,5233	0,785	0
sinh	0,2854	0,3928	0,4586	0,8946
yskahrad	0,28944	0,40369	0,4764	1,1076
vyskah	16,592	23,141	27,313	63,495
sina	0,02087	0,53249	0,7954	0
arad	0,02087	0,56154	0,9196	0
astu	1,1966	32,1907	52,72	0
sklonrad	0	0	0	0
adif	1,1966	32,1907	52,72	0
adifrad	0,02087	0,56154	0,9196	0
cosg	0,2854	0,3928	0,4586	0,8946
grad	1,2813	1,167	1,094	0,4631
gstu	73,45	66,903	62,731	26,55

Table 2: Input and output data

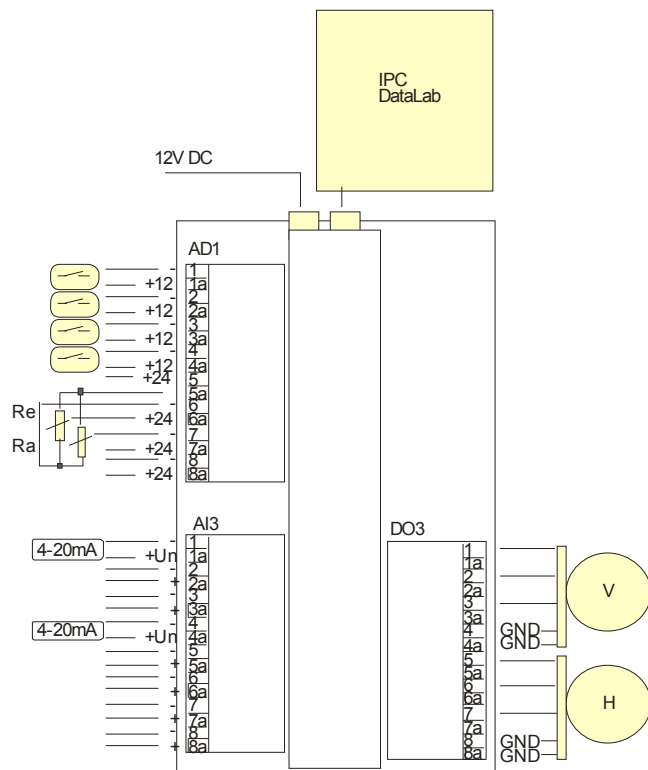

Fig. 4 Block scheme of control system of tracking

V. RESULTS OF PILOT OPERATION

Pilot operation of DE10 was running from August of 2010 to the end of March 2011. This period was chosen to test the operation of panel in the winter lower temperature and in the autumn or spring the higher temperature.

The current results are positive. There were obtained the positive experience:

- Mechanical part: is satisfactory, it is robust, resistance to outdoor condition, operation was running by -25°C , good protection against rain, temperature and moisture.
- Electrical part: function of step motors is without any problems, the end switch needed to change at the test beginning (the old ones have problems with water).

System part:

- The central unit has been running without any collision, only some problem after drop-out of power (it has to restart sometimes manually)
- Measuring sensors show out 100% functionality, all tests of accuracy were positive.
- The software of local application DE10 has been working with full functionality, without mistakes. There was set up newly the part of position control of elevation according to results of testing. The application of server of LABI has been got processed intermediate after the start of function and hasn't been had any problems during pilot operation.
- User part generally was programmed after intensive discussing and analyzing of submission. There were applied the experience of operation of older experiments: DE01, DE05 too. Very high significance has the automatic regime which is running permanent and date is archived. The date bank is the date bank of sun irradiation for last days. The manual regime is fit for individual studying, for testing of panel for moment irradiation.

The consumption of the electrical power of photovoltaic system is solved according to scheme in fig. 5.

The electrical power of photovoltaic panel on pins plus and minus is connected to measurement system at terminal points X1/14 and X1/13. The electrical voltage of panel is measured at resistors and connected to input AI7 of central unit. The electrical current from panel is measured in shunt resistor and is connected to input AI6 of central unit. The electrical power is consummated in outdoor resistor R_B . The resistor is cooled and the sun energy is changed into heat.

We have measured the data about sun radiation as the input light or visible radiation energy. Therefore we have to calculate over the units lux to W/m^2 . The changing is necessary to have as a results of energy efficiency. Then the sun radiation is changed to electrical power. and the voltage and current of consummated output power without problems.

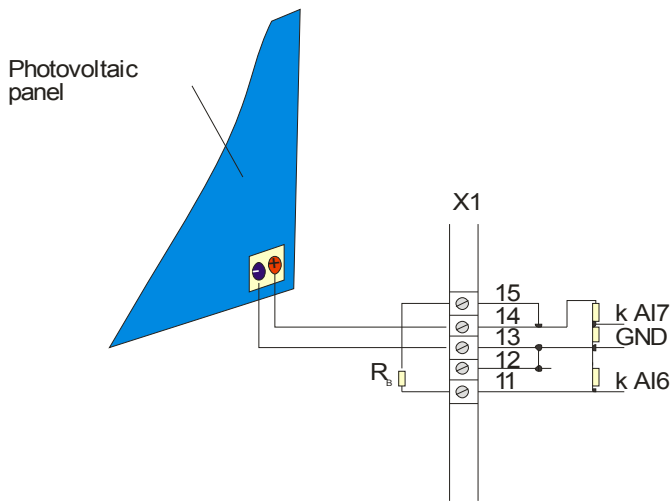

Fig. 5 Scheme of consumption of electrical energy

Electromagnetic sun irradiation is evaluated as irradiation flux Φ_e (W) according the formula:

$$\Phi_e = \int \Phi_{e,\lambda} \cdot d\lambda \quad (1)$$

where is $\Phi_{e,\lambda}$ spectrum flux to wavelength λ (W/m) calculated according to Planck low.

Other formula is significant, there is irradiation E_e (W/m²):

$$E_e = \frac{d\Phi_e}{dA} \quad (2)$$

calculated according to Stephan Boltzmann low .

Irradiation after radiation of panel is M_e (W/m²) and has the value

$$M_e = E_e \cdot k_p \quad (3)$$

where is k_p coefficient of efficiency of the change of energy in panel.

In system DE10 there is measured the irradiation as a light irradiation E_v in (lux). The formula for description of it is:

$$E_v = \frac{d\Phi_v}{dA} \quad (4)$$

where is Φ_v light flux (lm), A area (m²).

The conversion unit of lumen (light irradiation flux) to unit W/m² (electromagnetic irradiation) is possibly according to formula:

$$\Phi_e = \frac{E_v \cdot A}{K_{ve}} \quad (5)$$

where is K_{ve} a constant (lm/W). Regression analyze gets the value of $K_{ve}=103,816$.

For the testing of calculation according to formulas from (1) up to (5) there is prepared a program in the BASIC Language. The source text is in the next table 3.

```
'Program výpočtů solární iradiace/Evaluating software of
evaluation of soler irradiation
[start]
```

```
print "Výpočty pomocných údajů/Calculation of auxiliary
data"
input "Zadání odklonu roviny na zemi/entry of solar
radiation deflection fi(°):"; fi
input "Zadání znečistění atmosféry/entry of turbidity of
atmosfere Tv (-):"; tv
input "Zadání hodnoty měření lx/entry of measured value
lx (lux):"; lux
input "Zadání plochy panelu/entry of area of panel A
(m2):"; A
input "Zadání ele výkonu panelu panelu/entry of power of
panel Wme (W):"; Wme
```

```
' pomocné výpočty /auxiliary evaluation
mfi=1/(cos(fi*3.14/180))
cosfi=cos(fi*3.14/180)
av=1/(10.1+0.045*mfi)
Esmax=133880 'max hodnota osvětlení na hranici atm
Esf= (Esmax*cosfi*EXP(-1*av*tv*mfi))
```

```
' výpočty měření na panelu/evaluation of measurement
Kve=97.93708851
Ew=lx/Kve
Wpanel=Ew*A
ucin=Wme/Wpanel
```

```
print fi
print tv
print lux
print A
Print Wme
print cosfi
print mfi
print av
print Esf
print Ew
print Wpanel
print ucin
```

```
goto [start]
```

Table 3: Source text of efficiency evaluation

The results of the calculation of panel efficiency are in the table 4 for four situation. The red data are input value and there are the data from measurement on the panel..

The main results are value of efficiency. When there are some higher sun irradiation (measurement T11, T12, T13 is the efficiency above 8 %. By the irradiation about 38 klux there are the efficiency below 6,6%.

The evaluation of irradiation in Watt units and efficiency is calculated according to procedure:

- Theoretical solar irradiation, maximum measured on the area of Earth is:

$$E_{s,max} = E_{v,\varphi} \cdot K_v \quad (\text{lux}) \quad (6)$$

where is $K_v = K_m \cdot V(\lambda) \cdot d\lambda = 97,3275 \text{ (lx/W)}$

	T11	T12	T13	T14
solar radiation deflection ϕ (°)	1	1	1	1
turbidity of atmosphere T_v (-)	1	1	1	1
lighting value I_x (lux)	62927	59879	64888	38069
panel area A (m ²)	0,5	0,5	0,5	0,5
power of panel W_{me} (W)	27	26,30	27,50	12,70
$\cos \phi$ ()	0,9998	0,9998	0,999848	0,999848
$m \phi$ ()	1,0002	1,0002	1,0002	1,0002
a_v ()	9,86E-02	9,86E-02	9,86E-02	9,86E-02
$E_{s\phi}$	121292,6	121292,6	121292,6	121292,6
E_w	642,52	611,40	662,55	388,71
W_{panel} (W)	321,26	305,70	331,27	194,35
efficiency (%)	8,40%	8,60%	8,30%	6,53%

Table 4: Results of the calculation of panel efficiency

- Solar irradiation for concrete position and situation is:

$$E_{s,\phi} = E_{s,max} \cdot \cos(\phi) \cdot e^{(-a_v \cdot T_v \cdot m(\phi))} \quad (\text{lx}) \quad (7)$$

where is

- ϕ deflection of sun shining,
- $m(\phi)$ function $m(\phi) = 1 / \cos(\phi)$,
- T_v is a turbidity of atmosphere (= 2,45 for countryside, =3,3 for towns, 5,5 for industry)
- a_v is function $a_v = \frac{1}{(10,1 + 0,045 \cdot m(\phi))}$
- Recomputation units lux to W is by formula:

$$E_{r,max} = E_{s,max} / K_v, \text{ (lx) for maximum, and} \quad (8)$$

$$E_{r,\phi} = E_{s,\phi} / K_v \text{ (lx) for real position.} \quad (9)$$

VI. POSSIBILITY OF ENLARGEMENT AND IMPROVEMENT OF FUNCTION

Experiences of pilot operation of DE10 have showed some possibility and given ideas to enlargement and improvement of current functions. They are at the moment:

1. The construction of DE10 is prepared as open to enlargement the kinds and areas of panels. There are discussed the possibilities of expand on new plastics panels and on panels with contractors.
2. The new project solves expanding on measurement of air quality in environment: (CO_2 , NO_x , CO , eventual VOC).
3. The new access to DE 10 and LABI will use new mobile phones. The application SW of DE10 and server's SW will have new html server program.

The scheme of project of enlargement and improvement is in fig. 6.

The current panel of monocrystalline technology is added the photovoltaic panel of polycrystalline technology. The measurement of light irradiation is added the equipment of global sun irradiation measurement. The measurement of environment quality is added the measurement of CO_2 and

VOC concentration.

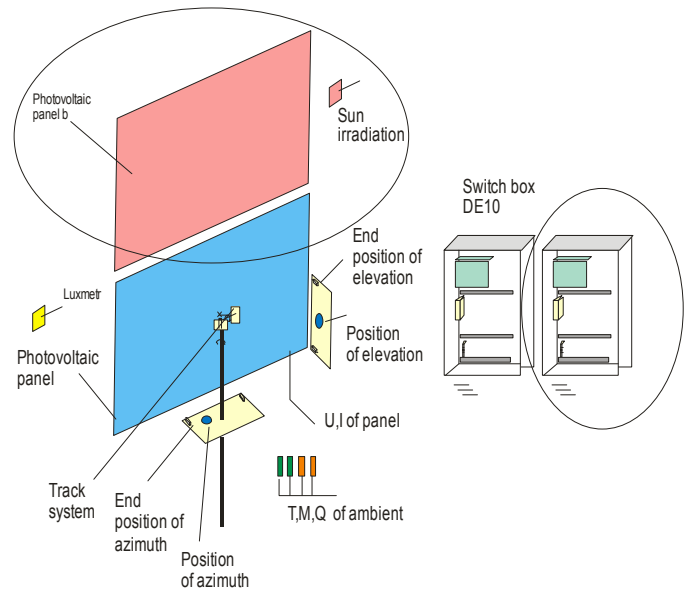

Fig. 6 Scheme of enlargement and improvement of photovoltaic system DE10

VII. EXAMPLES OF USING DE10

Access to the system LABI and to the experiment DE10 is free [6]-[10]. Calling of application is by URL: labi.fai.utb.cz. There is possibility to study system and open the experiment and use it. The first window of LABI is in fig. 7 it is in appendix. That is the entry window of system LABI.

After the choosing the system DE10 – Solar panel in the first window is opened next windows. In the fig.8 there is a picture and a list of measured data. Next window is in fig. 9 and contents the time history of the measured data.

If the access is currently, there is necessary to registry. Then is opened the experiment and it can be started the experiment.

The using has three regimes:

1. Export the archived data pro set date and time. The output is a date file of all measured date in the text format for next recalculation or study post mortem.
2. Hand regime for a short measurement for set the position of panel azimuth and elevation, the output is the date file with all measured date.
3. Automation regime for a short measurement for calculated position.

The measured date in the files are archived at the set name and the format is „csv“.

VIII. CONCLUSION

The experiences of pilot operation confirm operating, functionality and signification of system DE10 at the period 6 months. The equipment was in the outdoor environment with influences of winter environment (e.g. up to -22°C .) and in the autumn up to $+32^\circ\text{C}$ in the ambient. Parallel there were tested

the all measuring loops. The results of pilot operation release the system DE10 to use in the full end-user operation.

REFERENCES

- [1] HRUŠKA,F. Internet a laboratoře integrované automatizace (The Internet and the Integrated Automation Laboratory). Jemná mechanika a optika, 2007, č. 2, s.64-66. Praha: Fyzikální ústav Akademie věd České republiky, 2006. ISSN 0447-6441.
- [2] HRUŠKA,F. Laboratoře integrované automatizace na UTB ve Zlíně (The Integrated Automation Laboratory at the UTB in Zlin). AUTOMA, roč. 51, 2007, č. 2, s.43-46. Praha: FCC Public, 2007. ISSN 1210-9592.
- [3] HRUŠKA F.: Experimental Model of Photovoltaic Systems. In: Proceedings of the 12th International Research/Expert Conference “Trends in the Development of Machinery and Associated Technology” TMT 2008, pp. 645-648. ISBN 978-9958-617-41-6. Istanbul, Turkey, 26.-30.8.2008.
- [4] HRUŠKA F.: Experimental Photovoltaic System. In: Proceedings of the 20th International DAAAM Symposium “Intelligent Manufacturing &Automation” DAAAM 2009, pp. 923-924. ISBN 978-3-901509-70-4. Vienna, Austria, 25-28.11.2009.
- [5] HRUŠKA F.: Photovoltaic System in System LABI. In: Proceedings of the 14th WSEAS International Conference on Systems “Latest Trends on Systems”, (Part of the 14th WSEAS CSCC Multiconference, pp. 498-499. ISBN 978-960-474-214-1. Corfu island, Greece, 22-24.7.2010.
- [6] HRUŠKA,F. Internet a laboratoře integrované automatizace (The Internet and the Integrated Automation Laboratory). Jemná mechanika a optika, 2007, č. 2, s.64-66. Praha: Fyzikální ústav Akademie věd České republiky, 2006. ISSN 0447-6441.
- [7] HRUŠKA,F. Laboratoře integrované automatizace na UTB ve Zlíně (The Integrated Automation Laboratory at the UTB in Zlin). AUTOMA, roč. 51, 2007, č. 2, s.43-46. Praha: FCC Public, 2007. ISSN 1210-9592.
- [8] HRUŠKA F.: Experimental Model of Photovoltaic Systems. In: Proceedings of the 12th International Research/Expert Conference “Trends in the Development of Machinery and Associated Technology” TMT 2008, pp. 645-648. ISBN 978-9958-617-41-6. Istanbul, Turkey, 26.-30.8.2008.
- [9] HRUŠKA F.: Experimental Photovoltaic System. In: Proceedings of the 20th International DAAAM Symposium “Intelligent Manufacturing &Automation” DAAAM 2009, pp. 923-924. ISBN 978-3-901509-70-4. Vienna, Austria, 25-28.11.2009.
- [10] HRUŠKA F.: Photovoltaic System in System LABI. In: Proceedings of the 14th WSEAS International Conference on Systems “Latest Trends on Systems”, (Part of the 14th WSEAS CSCC Multiconference, pp. 498-499. ISBN 978-960-474-214-1. Corfu island, Greece, 22-24.7.2010.

Author(s): Assoc.Prof. Frantisek HRUSKA, Ph.D. from Tomas Bata University in Zlin, Faculty of Applied Informatics, Nad Stranemi 4511, CZ-76005 Zlin, Czech Republic, E-mail: hruska@faiutb.cz, URL: <http://www.fai.utb.cz>, Phone: 00420 57 6035246

APPENDIX

The screenshot displays the first window of the system LABI website. The browser's address bar shows the URL <http://labi.fai.utb.cz/indexEN.html>. The page content is organized into several sections:

- General description**: A main heading with a small flag icon.
- Individual tasks**: A list of tasks including DE1-Temperature regulation, DE2-Heating plant system, DE3-Flowmeters, DE4-Asynchronous motors and control of rotation speed, DE5-Biochemical processes, DE6-Communication RS232 and Ethernet, DE7/8-Levels of the tanks, DE7/9-Light sources, and DE10-Solar panel.
- Photograph**: A large image showing the exterior of a modern laboratory building.
- Text description**: A paragraph stating: "The project Laboratories of integrated automation (LABI) is solved in the development program. No. 663/2005/A/a of the Ministry of Schooling, Young and Physical Education of the Czech Republic. The main purpose is to build up new modern laboratories with remote real teaching experiments accessible locally and remotely in the Internet. The LABI will be used in some education fields related with the industrial automation and the applied informatics. LABI will be used by students and teachers and will become a part of the global solution of laboratories in the Internet."
- Footer**: Logos for Tomas Bata University in Zlin, Faculty of Applied Informatics; FAI | UTB | Moravian Instruments; and Powered by Control Web 4.5.

Fig.7 The first window of system LABI

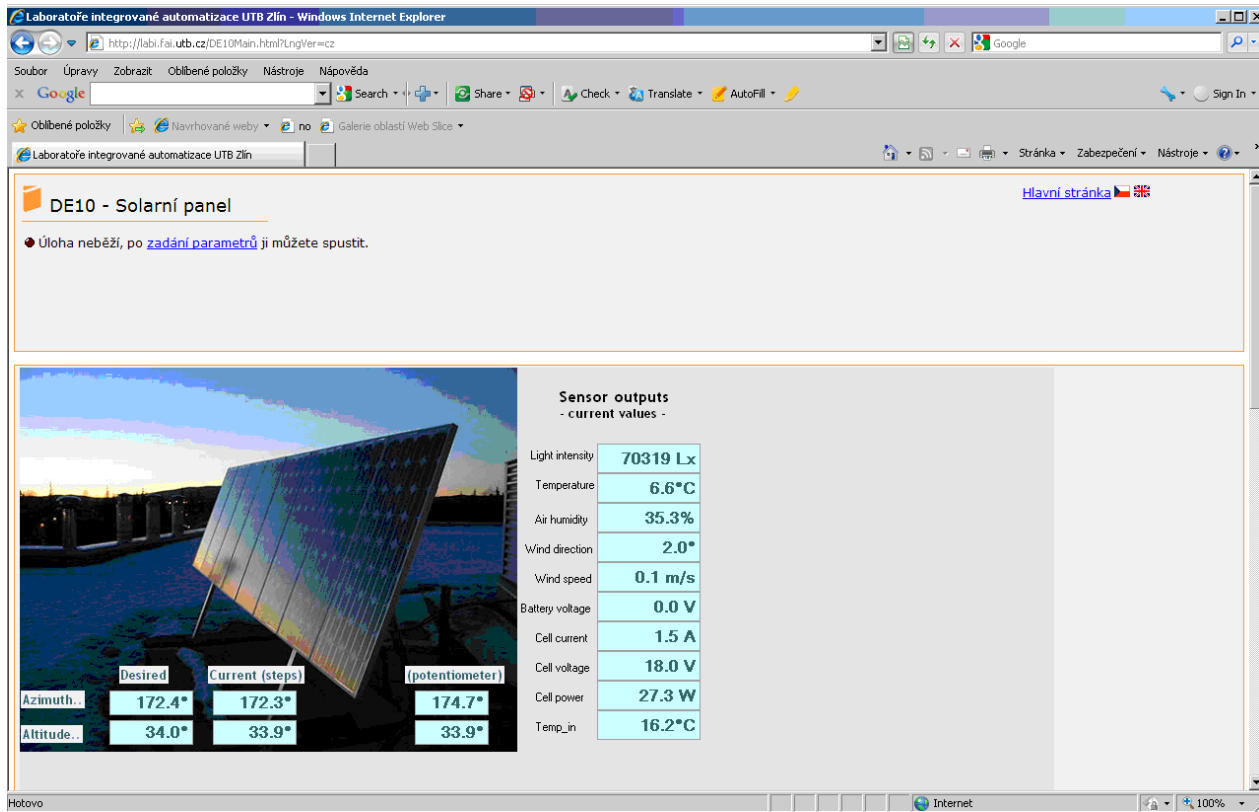

Fig.8 The window of DE10 – the table of measured data

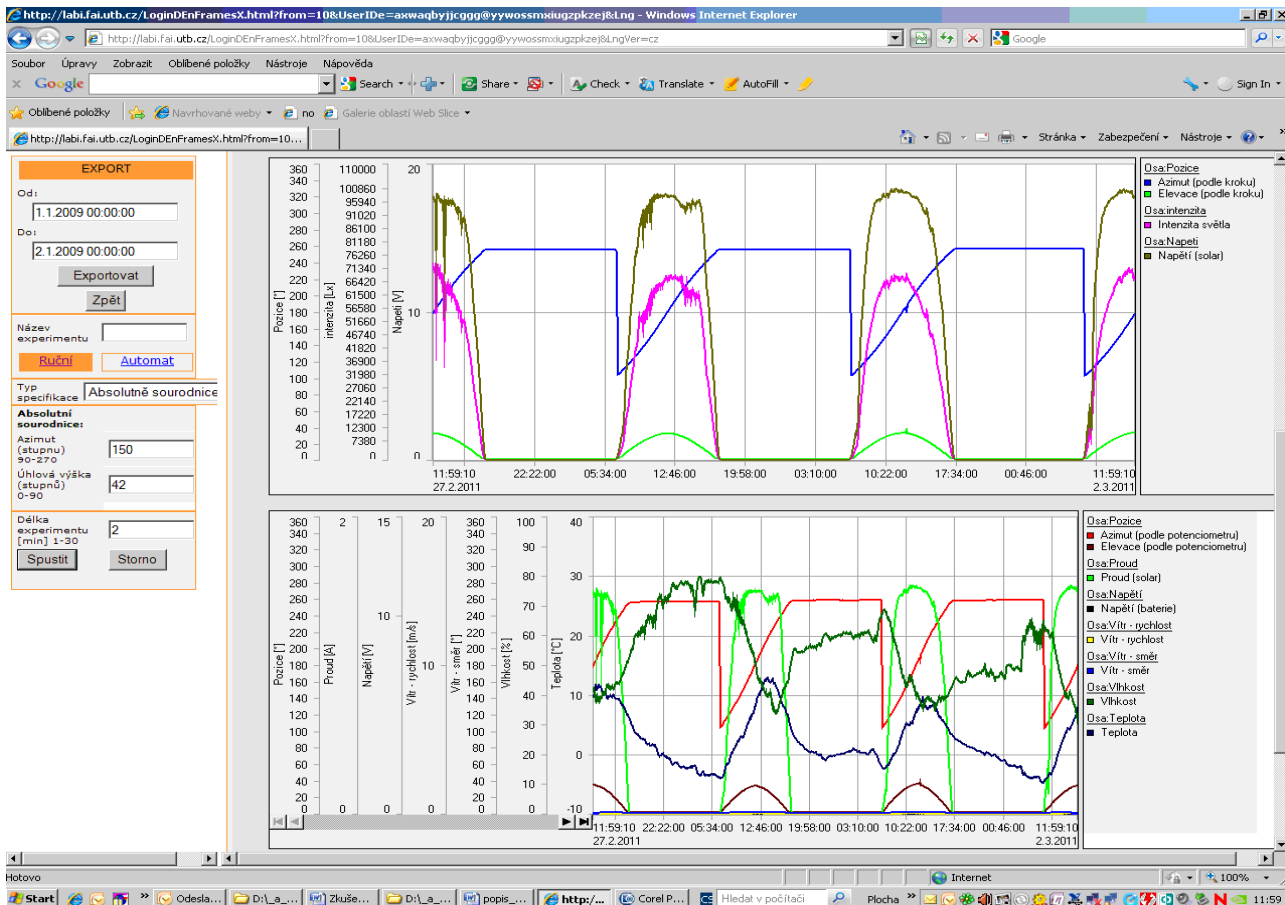

Fig.9 The windows of DE10 – the graphs of measured data

ACKNOWLEDGMENT

This work was supported in part by the Ministry of Education, Youth and Sports of the Czech Republic under grant No. MSM 7088352102: “Modeling and control of processes of natural and synthetic polymers”.