

# Use of Ferrofluids for Bushing Cooling and On-Line Monitoring

S.D. NEDEL CUT, V. PROCA, D.M. PURCARU

**Abstract** - This paper reviews all the advantages of the on-line monitoring and presents an equipment for on-line monitoring of bushings, which is the own contribution of specialists who are the authors of this paper. The paper presents a study of the temperature field, using the finite element method. For carrying out this study, the 3D modelling of the above mentioned bushing was performed. The analysis study is done taking into account the extreme thermal stresses, focusing at the level of the first cooling wing section of the ceramic insulator. This fact enables to justify the  $\tan\delta$  variation in time, depending on the transformer loading and the environmental conditions. With a view to reducing the variation of dielectric losses in bushing insulation, the use of ferrofluids instead of mineral oils is proposed.

**Keywords** – monitoring, dielectric losses, ferrofluids, bushing

## I. INTRODUCTION

Power transmission and distribution systems from the economically developed countries are already aged being, in many cases, more than 30 years old. All the fixed assets of the power systems have a standardized life time of maximum 30 years.

From now on, any equipment is in danger to fail at any times with no previous warning.

Under these conditions the on-line monitoring is one of the most useful methods for prolonging the life time up to the failure time limit and for replacing the assets or recovering them in the last moment.

Because the bushing is a key element in the operation of electrical power equipment, its safe operation is a special issue because its degradation leads, in many cases, to the explosions followed by fires with very grave consequences for the stations and the substations.

If up to the present the time-based maintenance (TBM), with periodical revisions, was used, in the last years one tries to find solutions to pass to the condition-based maintenance (CBM) which allows the minimization of the costs, the prolongation of equipment life time and the decrease of the risks of failure in exploitation with grave consequences.

Based on the authors' experience in the field of monitoring of electric networks parameters and power transformers thermal condition [2], a digital equipment for the monitoring of bushings insulation, with an original conception, was finalized.

## II. CONTRIBUTIONS TO THE CONDITION-BASED MAINTENANCE OF THE BUSHINGS BY THEIR MONITORING

### A. The importance of on-line monitoring of bushings

The damage of bushings is one of the main causes leading to the improper operation of the transformers or even to the explosions. The statistics confirmed that 30% of the transformer damages are due to capacitor-type bushings. The European statistics show that 80% of the damaged bushings are between 12 and 20 years old and therefore the monitoring is necessary even before the middle of their life time [1].

The high electric field gradients in the bushing insulation and the high working temperature contribute to the acceleration of insulation ageing.

The explosion of the bushing can damage the transformer tank, can generate an extended fire by transformer oil ignition, and fire in the bundle of cables in the electric switch box or in the control room through the secondary wiring.

A damage of the bushing leads to financial losses (between 1 and 3 million of dollars) to the insurers, both for physical damages and for the disturbances of the affairs in the companies they are serving.. These losses can reach, in exceptional situations, tens million of dollars.

The explosion can generate material damages and human life losses because of the porcelain pieces spread at long distance and with a very high speed.

The traditional diagnosis systems of the bushing insulation are based on periodical measurements of insulation loss factor, once within 2-3 years. In such case, it is necessary to put the transformers out of service and to measure  $\tan\delta$  at an applied voltage of 10 kV. The disadvantages of this traditional method for monitoring the bushing insulation are the following:

-The testing frequency arbitrarily chosen is not usually correlated with the failure rate development. The practice proved that the period between the measurements must not exceed 100 days to detect 95% from the defective bushings, and this is practically unacceptable;

-The measurements for  $\tan\delta$  performed at an applied voltage of 10 kV are not relevant for the actual condition of the bushing insulation. The measurements at rated voltage, performed on the bushings where partial discharges appear, showed values of 5-8 times higher than those measured at 10

---

Manuscript received March 25, 2007; Revised received November 28, 2007.

S.D. NEDEL CUT is with the Research and Development and Testing National Institute for Electrical Engineering-ICMET Craiova, Romania (corresponding author to provide phone: +40 351 404 889; fax: +40 351 404 890; e-mail: dnedelcut@icmet.ro).

V. PROCA, was with Research and Development and Testing National Institute for Electrical Engineering-ICMET Craiova (e-mail: vproca@icmet.ro).

D.M. PURCARU is with the University of Craiova, Romania(e-mail: dpurcaru@yahoo.com).

kV. The oil deterioration at high temperatures generates chemical modifications and sediment accumulations leading to the failures of the bushings. The detection of this type of fault at the voltage of 10 kV can be very difficult, even by  $\tan\delta$  measurement at the rated voltage.

-The traditional testing methods require a lot of work and the putting out of service for a long time.

By these reasons it is preferable to use on-line monitoring methods for the bushings.

Bushing monitoring methods known at present are presented below:

- use of a modified Schering bridge, where special methods are taken for suppressing the disturbances (standard capacitor supplied at the low voltage side of a voltage transformer connected on the same phase as the tested object, replacement of the conventional null indicator by a microcontroller-based measuring device fitted out with adaptive filtration). The equipment has in its structure standard components which require special metrological verifications, is bulky and could be achieved with high costs.

The equipment achieved by this method implementation allows monitoring the dielectric dissipation factor ( $\tan \delta$ ), but is very expensive.

- vector addition of the capacitive currents of the bushings mounted on the three phases and detection of the unbalance current .

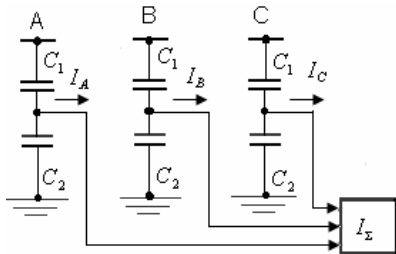

Fig. 1 block diagram of capacitive current acquisition

Where:

A, B, C – bushings under potential

$C_1$  - main capacity of the bushing

$C_2$  - capacity of the last layer of the bushing

$I_A, I_B, I_C$  - capacitive currents acquired at the bushing measuring terminals

$I_\Sigma$  - vector adder

On the basis of the analysis on the magnitude and phase of the unbalance current  $\Delta I_\Sigma$  the degree of modification for the dielectric properties of bushings is found; the disadvantage is that it does not present on line the value of  $\tan \delta$  for each bushing.

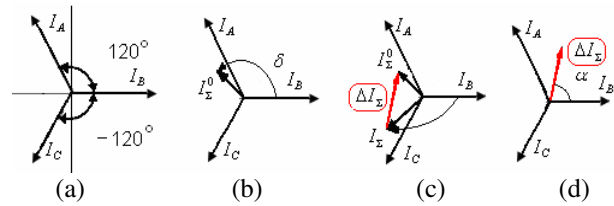

(a) balanced bushings

(b) determination of the initial unbalance current,  $I_\Sigma^0$ ;

(c) determination of the unbalance current  $I_\Sigma$ , and sum current  $\Delta I_\Sigma$ , taking also into account the initial unbalance current  $I_\Sigma^0$ ;

(d) determination of the unbalance current  $\Delta I_\Sigma$ , modulus and phase, related the phase B

Fig. 2 determination of the unbalance current  $\Delta I_\Sigma$

### III. DIGITAL EQUIPMENT FOR ON-LINE MONITORING OF BUSHINGS

For on-line monitoring of bushings it is ideal to monitor the time variation of dielectric losses and of bushings own capacity.

In a quasi-homogeneous dielectric, in homogeneous electric field, the losses in dielectric depend on the electric field strength and temperature. The losses increase proportionally to the square of the electric field strength but they strongly depend also on the temperature  $\theta$  in dielectric [6], [8].

$$P(\theta) = \frac{1}{2} \varepsilon_0 \varepsilon_r(\theta) \cdot E^2 \cdot \omega \tan \delta(\theta) \quad (1)$$

At high electric fields, the losses have even more accentuated increase related to the electric field strength.

The heat produced by Joule losses from the central conductor of the bushing generate also a temperature rise in the insulating material, which overlaps on that one due to the dielectric losses.

Because of dielectric losses, the alternating current which passes through a bushing is not purely reactive  $I_r$ , but it has an active component  $I_a$  named leakage current.

Let us consider an elementary capacitor with the area of the armature  $S$ , the thickness  $d$ , at the voltage  $U$  and the frequency  $f$ , which has the losses  $P$ :

$$P = p_\theta \cdot v \cdot E^2 \quad (2)$$

where :  $p_\theta$  are the specific volume losses ( $v$  = the volume of dielectric) at the temperature  $\theta$  and, at the stress with the electric field having the strength  $E$ :

$$I_a = \frac{P}{U} = \frac{p_\theta \cdot v \cdot E^2}{E \cdot d} = \frac{p_\theta \cdot S \cdot d \cdot E^2}{E \cdot d} = p_\theta \cdot S \cdot E \quad (3)$$

$$I_r = 2 \cdot \pi \cdot f \cdot U \cdot C = 2 \cdot \pi \cdot f \cdot E \cdot d \cdot \frac{S}{d} \cdot \epsilon_0 \cdot \epsilon_r =$$

$$= 2 \cdot \pi \cdot f \cdot \epsilon_0 \cdot \epsilon_r \cdot S \cdot E$$

$$\tan \delta = \frac{I_a}{I_r} = \frac{P_\theta}{2 \cdot \pi \cdot f \cdot \epsilon_0 \cdot \epsilon_r} \quad (5)$$

The phasor diagram is:

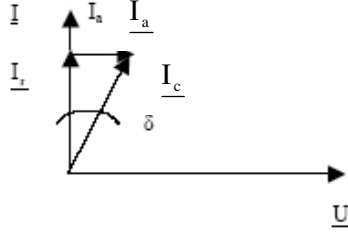

Fig. 3 the phasor diagram

The dielectric losses of a bushing are:

$$P = U \cdot I_a = U \cdot I_r \cdot \tan \delta = 2 \cdot \pi \cdot f \cdot U^2 \cdot C \cdot \tan \delta \quad (6)$$

The used measuring diagram is the classical one:

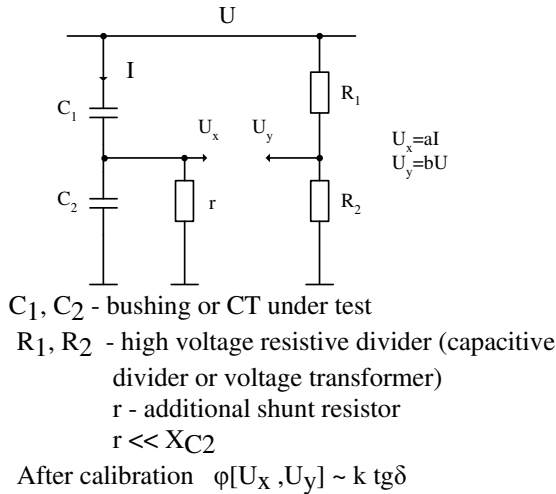

Fig. 4 the measuring diagram

For each monitored bushing the method presumes the acquisition of two signals: one signal taken over from the test tap of the bushing and the second signal, representing the reference voltage, taken over from the instrument transformer corresponding to the monitored bushing [3].

The taken over signals have non-sinusoidal periodical character and they have the following form:

$$f(t) = A_0 + \sum_{k=1}^{\infty} [M_k \cdot \cos(k\omega t) + N_k \cdot \sin(k\omega t)] \quad (7)$$

The implemented program performs the calculation of  $\tan \delta$  by the extraction of fundamentals from the sampled signals by a Fourier analysis algorithm.

The calculation algorithm presumes:

- determination of the coefficients  $M_k$  and  $N_k$  for the fundamentals of the two signals ( $k=1$ )

$$M_1 = \frac{2}{T} \int_0^T f(t) \cos(\omega t) dt \quad (8)$$

$$N_1 = \frac{2}{T} \int_0^T f(t) \sin(\omega t) dt \quad (9)$$

The coefficients  $M_1$  and  $N_1$  are determined for each acquired quantity.

- determination of initial phases of the fundamentals

$$\varphi_1 = \arctan \frac{M_1}{N_1} \quad (10) \quad \varphi_1' = \arctan \frac{M_1'}{N_1'} \quad (11)$$

where,

$\varphi_1$  = the initial phase of the fundamental of the signal taken over from the measuring terminal of the bushing;

$\varphi_1'$  = the initial phase of the fundamental of reference signal taken over from the measuring terminals of the voltage transformer corresponding to the measured bushing.

$$\text{Noting: } \delta_1 = \varphi_1 - \varphi_1' \quad (12)$$

The loss dielectric factor is:

$$\tan \delta = \tan(90^\circ - \delta_1) \quad (13)$$

For non-sinusoidal state we have:

$$u = \frac{1}{C} \int i dt \quad (14)$$

$$i = C \frac{du}{dt} = \sum_1^{\infty} \sqrt{2} k C \omega U_k \quad (15)$$

From here:

$$I_k = k C \omega U_k \quad (16)$$

Thus, by calculation, the own capacity of the bushing is obtained.

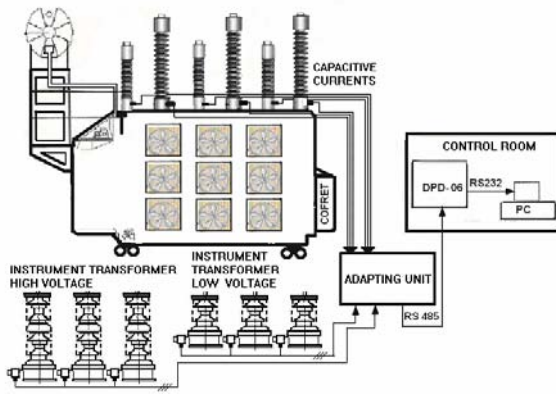

Fig. 5 monitoring equipment mounted in the station

IV. CALCULATION OF BUSHING HEATING UNDER LONG TIME DUTY AND THERMAL CAPACITY

The calculation is performed in a covering manner, supposing that the axial thermal flux is neglected, but taking into account the Joule losses in the terminal and the dielectric losses in the capacitor, also their variation with temperature. The external temperature is considered as being given:  $\theta_e$ .

Fig. 6 present the calculation model. The rated current  $I_N$  flows through the terminal with diameter  $d_e$ , generating on the unit of length the Joule losses:

$$P_0 = k_r \cdot \rho_0 \cdot (1 + \alpha_0 \cdot \theta_0) \cdot \frac{4}{\pi \cdot d_e^2} \cdot I_N^2 \tag{17}$$

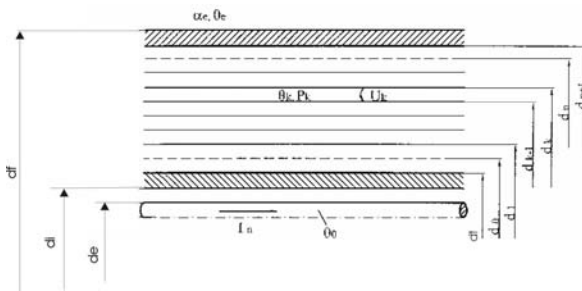

Fig. 6 bushing calculation model

Here,  $k_r$  is the skin effect factor,  $\rho_0$  is the resistivity of the terminal material and  $\alpha_0$  is the temperature coefficient at 0°C, and  $\theta_0$  is the terminal temperature in °C.

Further on, the increasing factor for the resistance of the solid circular cylindrical conductor is calculated.

One considers the case the solid circular cylindrical conductor with diameter  $d$ , resistivity  $\rho_r$  and temperature coefficient  $\alpha_r$  at the reference temperature  $\theta_r$  and relative permeability  $\mu_r$ , in sinusoidal alternating current having the frequency  $f$ .

One calculates firstly the resistivity  $\rho_0$  and the temperature coefficient  $\alpha_0$  at 0°C:

$$\rho_0 = \rho_r \cdot (1 - \alpha_r \cdot \theta_r), \alpha_0 = \frac{\alpha_r}{1 - \alpha_r \cdot \theta_r} \tag{18}$$

One notes:

$$\xi_0 = \frac{d}{4} \cdot \sqrt{\frac{2 \cdot \pi \cdot f \cdot \mu_0 \cdot \mu_r}{\rho_0}} \tag{19}$$

$$\xi = \frac{\xi_0}{\sqrt{1 + \alpha_0 \cdot \theta}} \tag{20}$$

if  $\theta$  is the conductor temperature.

From the theory of the skin effect, the following expression of the complex inner impedance of the cylindrical conductor is set:

$$\underline{Z}_i = R_{eli} + j \cdot X_{eli} = R_{el0} \cdot \underline{k}_z; \underline{k}_z = \frac{\zeta \cdot J_0 \cdot (2 \cdot \zeta)}{J_1 \cdot (2 \cdot \zeta)} \tag{21}$$

where  $R_{el0}$  is the direct current resistance of the conductor:

$$R_{el0} = \rho_0 \cdot (1 + \alpha_0 \cdot \theta) \cdot \frac{4 \cdot l}{\pi \cdot d^2} \tag{22}$$

By  $\zeta$  the complex variable was symbolized:

$$\zeta = \xi \cdot j^{3/2} \tag{23}$$

and  $J_0$  and  $J_1$  are Bessel functions of first kind, order 0 and 1.

Taking into account the shape of the series giving these functions:

$$J_0 \cdot (2 \cdot \zeta) = \sum_{k=0}^{\infty} \frac{(-1)^k}{(k!)^2} \cdot \zeta^{2k} \tag{24}$$

$$J_1 \cdot (2 \cdot \zeta) = \zeta \sum_{k=0}^{\infty} \frac{(-1)^k}{(k!)^2 \cdot (k+1)} \cdot \zeta^{2k} \tag{25}$$

The following expression is derived:

$$\underline{k}_z = \frac{1 - \zeta^2 + \frac{1}{4} \cdot \zeta^4 - \frac{1}{36} \cdot \zeta^6 + \dots}{1 - \frac{1}{2} \cdot \zeta^2 + \frac{1}{12} \cdot \zeta^4 - \frac{1}{144} \cdot \zeta^6 + \dots} = \frac{\sum_0^{\infty} \underline{a}_k}{\sum_0^{\infty} \underline{b}_k} = \frac{\sum_0^{\infty} (u_k + j \cdot v_k)}{\sum_0^{\infty} (x_k + j \cdot y_k)} \tag{26}$$

The coefficients of the series from the numerator and denominator are determined step by step, using the algorithm:

$$\underline{a}_1 = 1 \text{ and then } \underline{a}_{k+1} = -\underline{a}_k \cdot \left(\frac{\zeta}{k+1}\right)^2 \text{ și } \underline{b}_k = \frac{\underline{a}_k}{k+1} \tag{27}$$

respectively  $\underline{u}_1 = 1$  and then

$$x_k = \frac{u_k}{2k+1}, v_k = \xi^2 \cdot \frac{x_k}{2k+1}, y_k = \frac{v_k}{2k+2}, u_{k+1} = -\xi^2 \cdot \frac{y_k}{2k+2} \quad (28)$$

The series being with oscillating sign terms, they are added until the modulus of the added term decreases below the modulus of the sum multiplied with relative tolerance.

The algorithm is a stable one, in simple accuracy, up to  $\xi = 5$ , limit sufficient for practice. Further on, asymptotic developments could be used.

The factor for increasing the resistance,  $k_r$ , represents the real part of the factor  $\underline{k}_z$ .

$$k_r = \frac{R_{ei}}{R_{e0}} = \text{Re}(\underline{k}_z) \quad (29)$$

Note – the factor  $\underline{k}_z$  has the significance  $k_r + \frac{j \cdot x_0 \cdot k_x}{R_{e0}}$ ,

where  $x_0$  is the inner reactance at direct current distribution:  $\frac{x_0}{R_{e0}} = \frac{\xi^2}{2}$  to the cylindrical conductor.  $k_x$  is the factor

for changing the inner reactance of the cylindrical conductor, due to the skin effect.

**Observation** – For bushings with rated currents up to 2500 A the skin effect within the current path could be neglected.

The terminal is inside the guiding tube with inner diameter  $d_i$ . It results a thermal resistance per unit of length:

$$R_0 = \frac{1}{2 \cdot \pi \cdot \lambda_u} \cdot \ln \frac{d_i}{d_e} \approx \frac{1}{\pi \cdot \lambda_u} \cdot \frac{d_i - d_e}{d_i + d_e} \quad (30)$$

Towards the environment, the terminal is bounded by a flange with outer diameter  $d_f$  and it transmits heat to the environment with temperature  $\theta_e$  by a release factor  $\alpha_e$  (16 - 32 W/m<sup>2</sup> C). It results a thermal resistance per unit of length

$$R_e = \frac{1}{\pi \cdot \alpha_e \cdot d_f} \quad (31)$$

If the bushing flange is fixed on the transformer tank, one could consider  $R_e \approx 0$ , and for  $\theta_e$  the maximum temperature of the oil at the level of transformer cap ( $\theta_e \approx 90^\circ\text{C}$ ) is taken.

The capacitor bushing itself is made of  $n$  layers numbered 1... $n$ , from inside towards outside. The layer numbered by  $k$  is comprised between the diameters  $d_{k-1}$  and  $d_k$ , has a middle temperature  $\theta_k$ , the voltage  $U_k$  is applied on it; dielectric losses per unit of length,  $P_k$ , are developed within the layer. On each diameter  $d_k$  an enclosure (foil) with axial length  $l_k$  is located. The geometric permeance per unit of length for the layer  $k$  is symbolized by  $\Lambda_k$ :

$$\Lambda_k = \frac{2\pi}{\ln \frac{d_k}{d_{k-1}}} \approx \pi \cdot \frac{d_k + d_{k-1}}{d_k - d_{k-1}}, k \in (1, n) \quad (32)$$

The dielectric losses per unit of length for the layer  $k$  are

expressed as:

$$P_k = p_d \cdot \Lambda_k \cdot e^{\sigma(\theta_k - \theta_d)} \cdot U_k^2, k \in (1, n) \quad (33)$$

where  $p_d$  is the volume density of the dielectric losses at reference temperature  $\theta_d$  and for the unit of electric field strength, and  $\sigma$  is the temperature coefficient for the exponential variation of specific losses.

Note – In general, the relation from below is valid:

$$p_d = 2 \cdot \pi \cdot f \cdot \epsilon_0 \cdot \epsilon_r \cdot \text{tg} \delta \quad (34)$$

where  $f$  is the frequency,  $\epsilon_0$  is the vacuum permittivity,  $\epsilon_r$  is the dielectric relative permittivity and  $\delta$  is the loss angle.

The voltage  $U_k$  applied to the layer results from the voltage  $U_m$  applied to the bushing.

$$U_k = U_m \cdot \frac{S_k}{\sum_{i=1}^n S_i}, k \in (1, n) \quad (35)$$

where by  $S_k$  the elastance of the layer  $k$  was expressed:

$$S_k = \frac{1}{\epsilon_0 \cdot \epsilon_k \cdot \Lambda_k \cdot l_k}, k \in (1, n) \quad (36)$$

By  $\epsilon_k$  it was noted the relative permittivity of the dielectric from layer  $k$ , which may depend on the temperature by means of the relation:

$$\epsilon_k = \epsilon_d \cdot e^{\zeta(\theta_k - \theta_d)}, k \in (1, n) \quad (37)$$

$\epsilon_d$  is the relative permittivity of the dielectric at the reference temperature  $\theta_d$ , and  $\zeta$  is the temperature coefficient.

The thermal resistance of the layer  $k$  is expressed by the relation:

$$R_k = \frac{1}{\lambda \cdot \Lambda_k}, k \in (0, n+1) \quad (38)$$

where  $\lambda$  is the thermal conductivity of the dielectric.

Fig. 7 present the diagram for bushing heating calculation:

One makes the notations:

$$Z_0 = R_0 + R_0' + \frac{R_1}{2}; Z_k = \frac{R_k + R_{k+1}}{2}, k \in (1, n-1); Z_n = \frac{R_n}{2} + R_e + R_e' \quad (39)$$

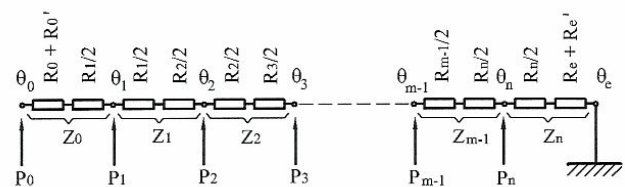

Fig. 7 diagram for bushing heating calculation

where by  $R_{\delta_0}$  și  $R_{\delta_e}$  there were expressed the thermal resistances of the possible buffer layers, no voltage, from bushing inside and outside (39).

Temperatures are immediately determined by the relation:

$$\theta_k = \theta_{k+1} + Z_k \cdot \sum_{i=0}^k P_i, \quad k \in (0, n) \quad (40)$$

Because losses depend on temperature, directly or by means of voltage distribution on layers, the resolution (40) is iteratively resumed, correcting each time the losses in accordance with the previously calculated temperatures, until a stationary solution (fixed point) is got.

During the experimentations improvements were made in order to reduce the influence of  $\tan \delta$  variation with the load, with the environment factors and with the electromagnetic disturbances, filtering the disturbing influences [4], [10], [12], [13]. It is necessary to get the variation tendency from the monitored data, using an adequate filter for eliminating the influences of the disturbing factors and for allowing to pass only the slowly variable component of the losses in the main insulation. Without any influence, the variation of the dielectric loss factor series would be very slow. Because of the influence of everyday and seasonal variations of the environment temperature and humidity the variation of the dielectric loss factor is cyclic. Besides, for the influence of the random effect of signal and electromagnetic disturbances transmission to a substation, there are many singular points in the data. Therefore the series of the on-line monitored dielectric loss factor ( $\tan \delta_m$ ) can be decomposed in the following way [7]:

$$\tan \delta_m(t) = \tan \delta(t) + \Delta \tan \delta_w(t) + \Delta \tan \delta_r(t) \quad (41)$$

where:  $-\tan \delta(t)$  is the main component which reflects the actual condition of the insulation which can be considered as the component with slow variation;  
 $-\Delta \tan \delta_w(t)$  is the component which reflects the everyday and seasonal influences on the environment and of other factors with slow variation (e.g. the load variation) and can be considered as the low frequency component;  
 $-\Delta \tan \delta_r(t)$  is the component which reflects the influences of the random factors including unusual climatic conditions, electromagnetic disturbances, etc. (its frequency band is wide and in the greatest part it is in the high frequency section).

If the tendency for  $\tan \delta(t)$  can be deduced from the initial data, the efficiency of the fault diagnosis can be much improved. If an adequate software recurrent filter is applied each component can be got directly from the loss coefficient series. The dielectric loss factor,  $\tan \delta$ , is filtered according to the relation:

$$\tan \delta_{pa} = \tan \delta_{p-1} + \frac{\tan \delta_{pm} - \tan \delta_{p-1}}{k} \quad (42)$$

where:  $\tan \delta_{pa}$  = the present displayed value

$\tan \delta_{p-1}$  = the previous value (measured and displayed)

$\tan \delta_{pm}$  = the present measured value

$k$  = the filtration coefficient

The interval between the readings is of the order of minutes. It is possible to attenuate random influences with a relatively short duration (minutes, hours and possibly days). As a result  $\tan \delta(t)$  is obtained when both the high frequency component and the low frequency one are eliminated. The filtration method is useful because it reduces the complexity of the diagnosis since the data can be directly processed, without the need of extended samples. The Figure 8 show, as example, the time variations of  $\tan \delta$  in a high-voltage substation at a transformer of 250 MVA, 400/200 kV.

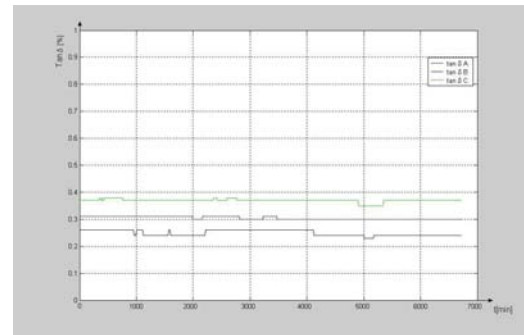

Figure 8 the time variation of  $\tan \delta$  at the bushings on the outputs of 400 kV

## V. MODELLING OF THE THERMAL FIELD FOR CAPACITOR-TYPE BUSHINGS

Following the variation of the dielectric losses during a week, the diagram from Figure 9 can be got:

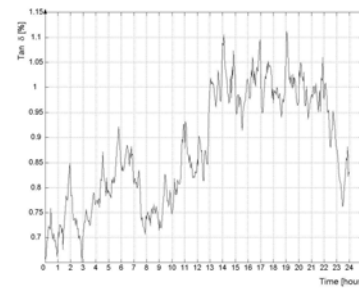

Figure 9 variation of the dielectric losses during a week

Thus, it is found that in certain days, at the time when the load peak appears, a significant increase of the dielectric loss value appears, which could be even 50%.

One could ask if there is certain theoretical explanation for this significant increase of the value measured on site.

That is why, together with the specialists from the University of Craiova, Faculty of Mechanics, one tried to find the theoretical explanation of this jump, analysing, by the finite element method, the temperature field under non-stationary condition, for the 123 kV, 1600 A capacitor-type bushing, during an autumn day

The determination of the average temperature for each element of the bushing is aimed at, knowing the temperature variation of the environment where the bushing is operating, the variation of the terminal heating as a result of network load variation, too. The 123 kV, 1600 A isolated outdoor bushing is shown in Figure 10.

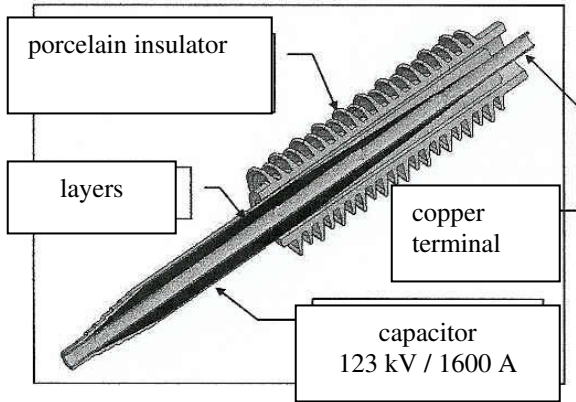

Figure 10 the 123 kV, 1600 A isolated outdoor bushing

The thermal study is done for the duration of an autumn day (for the time interval  $t = 0 \dots 24$  h). The temperature variation depending on time, for the environment where the bushing is operating, is given in Table 1:

Table 1

t[h]	0	1	2	3	4	5	6	7	8	9	10	11	12
$T_{aer}$	8	8	8	8	8	8	8	8	8	9	15	22	30
t[h]	13	14	14	16	17	18	19	20	21	22	23	24	
$T_{aer}$	30	30	30	30	25	25	20	20	15	15	10	8	

The temperature variation depending on time, for the isolated bushing terminal, as a result of the network load variation, is given in Table 2.

Tabelul 2

t[h]	0	1	2	3	4	5	6	7	8	9	10	11	12
$T_{ulei}$	50	50	50	50	50	50	50	55	60	65	65	70	75
t[h]	13	14	14	16	17	18	19	20	21	22	23	24	
$T_{ulei}$	75	75	75	75	75	80	90	90	90	75	65	50	

The graphical representations of these variations are shown in Figure 11:

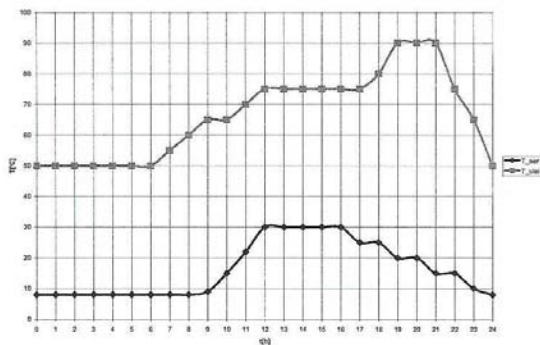

Figure 11 graphical representations of the temperature variation depending on time

The materials from which the bushing elements are made and their characteristics, which are required for the calculation, are given in Table 3:

Table 3

No.	element	material	$T[^\circ C]$	$\Lambda[W/mK]$
1	pipe	Al 99,5	0 200	229.11 229.2
2	ceramic insulator	porcelain	0 200	0.933 1.396
3	capacitor, layer	bakelite paper		0.16
4	terminal	Cu		390
5	transformer oil	oil	0 20 40	0.1257 0.1245 0.1233

Thermally, the most stressed section of the isolated bushing is the section corresponding to the first shed which is adjacent to the flange for fixing the bushing on the transformer tank (Figure 12)

In this paper it is considered the covering approximation, according to which the temperature variation of the flange for fixing the bushing on the tank is identical to the temperature variation of the oil from this.

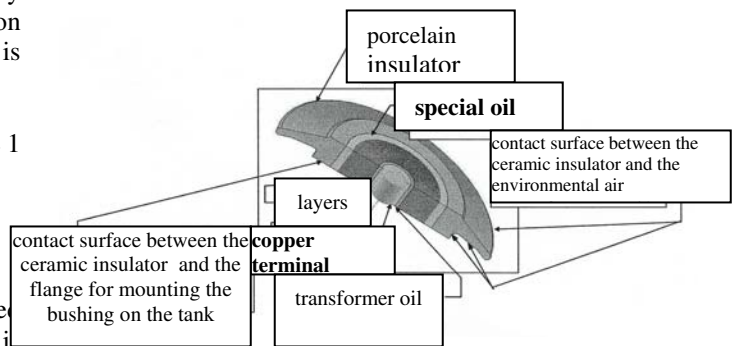

Figure 12 fixing the bushing on the transformer tank

The results of finite element simulation for a given time, regarding the average temperature on each element of the bushing, are given in the diagram from Figure 13:

As a matter of fact, this result is in accordance with the temperature distribution in the radial section of the bushing, for an operation time of interest, from the operation hour interval  $t = 0 \dots 24$  h.

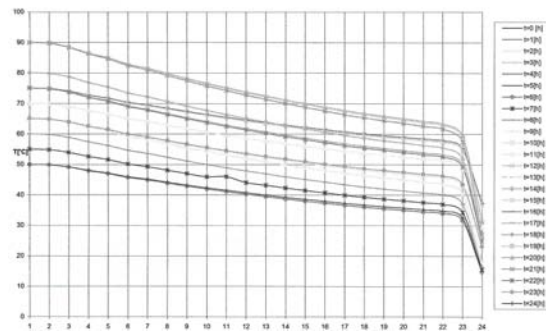

Figure 13 temperature variation on the elements of the 123 kV, 1600 A bushing, for a given operation time

In Figure 14 it is presented, for exemplification, such a temperature distribution on a radial section, corresponding to a peak hour (T = 20 h), when in the network there is a maximal supplying to the power consumers.

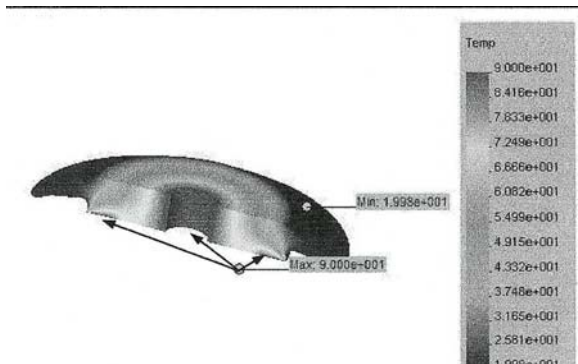

Figure 14 temperature distribution on a radial section

It is interesting to follow also the average temperature variation for each element of the bushing, along the 24 hours of operation, under the influence of the variation of the environment thermal load and power consumers connection to the network. This variation is shown in Figure 15:

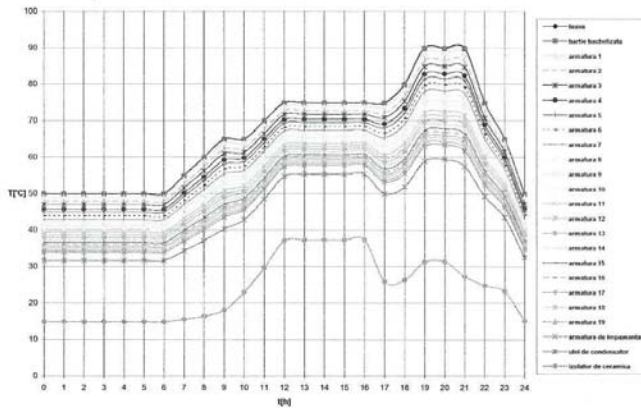

Figure 15 temperature variation on the elements of the 123 kV, 1600 A bushing

#### V. DEPENDENCE OF DIELECTRIC LOSS VARIATION ON THE LOAD FACTORS AND ENVIRONMENTAL CONDITIONS

By analysing the got results, it is noticed the identical behaviour of the dielectric layers, namely a significant increase of the average temperature, due to the increase of the environmental temperature, especially in the hours of load peak (17 – 22), even when the environmental temperature decreases significantly. But the material parameter depends also on the temperature, according to the relation:

$$\bar{p}_\theta = \bar{p}_{\theta_0} \cdot \exp[a(\theta - \theta_0)] \quad (43)$$

where „a” is a constant depending on the dielectric nature.

$$\text{Result: } \tan \delta = \tan \delta_0 \exp[a(\theta - \theta_0)] \quad (44)$$

For the bushings with resin-lacquered paper insulation, as a results of the laboratory experiments, the variation of  $\tan \delta$  as a function of temperature is:

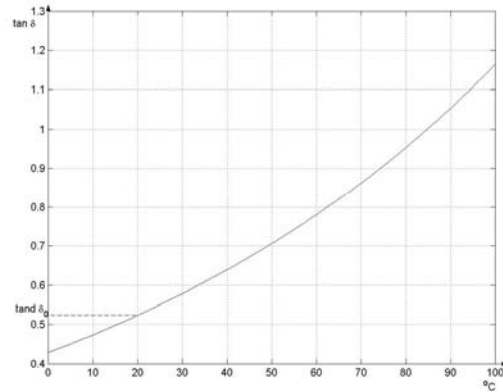

Fig. 16 the variation of  $\tan \delta$  as a function of temperature

From here, the explanation of the very high variation of the dielectric losses in the course of one day and, especially, the dependence on the network load variation can be very clearly obtained.

The application of this information is very useful because it confirms this accuracy of the measurements performed with this monitoring equipment placing confidence in this equipment utilization for protecting the capacitor-type bushings, the high power transformer, key-factors in the good operation of power systems, implicitly.

#### VI. USE OF FERROFLUIDS FOR BUSHING COOLING

As it results from the previous chapter, dielectric losses are closely depending on the temperature of the insulating body. The authors proposed themselves to study the improvement of the bushing cooling, by using ferrofluids instead of mineral oils.

Ferrofluids are suspensions of single domain magnetite particles with average diameters of approximately 10 nm stabilized by surfactants in carrier liquids. Ferrofluids have found application in a variety of engineered devices and systems for, among other things, lubrication and sealing of bearings. Recently, their potential utility in cooling of electrical equipments has been recognized.

It is known the change of the flowing depending on temperature, under the presence of electromagnetic field, this fact leading obviously to the improvement of cooling.

Taking into account the thermal model presented in Chapter 4, the overtemperature distribution on the bushing radius is got.

Laboratory experiments have been performed and an improvement of the cooling efficiency was found, decreasing the temperature of the insulating body by up to 10%, this fact



leading to a much lower variation of  $\tan \delta$  with temperature.

## VI. CONCLUSIONS

This work presents the advantages of on-line monitoring and especially of on-line continuous monitoring of the bushings on the power transformers. On-line monitoring methods for the own capacity of the bushings are known.

These ones present the disadvantage that information concerning the variation of the losses in dielectric and implicitly the ageing of the insulation is unknown. Other equipment monitors the vector addition of the capacitive currents through the insulation of the bushings and it detects their residual current; thus, it is sent information concerning the degradation of a bushing without detecting which one it is. The method is used especially in the United States where there are utilized bushings with paper armatures having applied a semi-conducting varnish on them, which migrates in time in oil. Following this disequilibrium all the 3 capacitor-type bushings are replaced. The method presented in this paper allows the early detection of the faulty bushing and its replacement before the appearance of a failure danger. At present 12 pcs. of this type of monitoring equipment are mounted and they are continuously monitored by the authors, but until now no non-conformities were found in equipment operation.

The presented method and equipment is the object of author's patent.

As a result of the experiments, the equipment has been provided with soft filtration enabling to remove the influence of load variation and environmental factors on the variation of dielectric losses, making possible a rigorous monitoring and just-in time alarm in case of a fault occurrence.

## REFERENCES

- [1] Arshad M., Islam S.M., Power transformer condition monitoring and assessment for strategic benefits, *Curtin University of Technology Department of Electrical & Computer Engineering, Perth, Australia.*
- [2] Nedelcuț D., Popa D., Monitoring, Control and Protection Equipment for Power Transformers, *Workshop "Technic Qualification and Transient Behaviour of Components of High Voltage Substation"*, Karlsruhe-Germania, 2002.
- [3] Nedelcuț D., Marinescu A., Sacerdoțianu D., Pătru I., Purcaru I., Equipment for HV Capacitor-Type Bushings (DPD) monitoring, „*The 7<sup>th</sup> International Conference on Live Maintenance – ICOLIM – 2004*”, București, România, 2004.
- [4]. Nedelcuț D., Bică M., Țălu M., Monitoring of Capacitor-Type Bushings Considerations Regarding the Influence on Thermal Field Distribution on Dielectric Losses, *IASTED Conference – Power and Energy Systems EuroPES 2005*, Benalmadena, Spain.
- [5] Nedelcuț D., Marinescu A., Sacerdoțianu D., Pătru I., Purcaru I. - Equipment for on-line monitoring of capacitor-type bushings, *CIGRE WORKING GROUP D1.02 Meeting, Romania, Eforie, 2005*
- [6] Roth, A., *Hochspannungstechnik*, IV edition, Wien, 1959
- [7] Wang N., Lu F.C., Li H.M., Analytical Processing of On-Line Monitored Dissipation Factor Based on Morphological Filter, *IEEE*, 2004
- [8] Ifrim A., Notinger P., *Electrotechnical Materials*, EDP, București, 1979
- [9] Kuchler A., Neumann C., Koch N., Loppach K., Krause C., Alff J.J., Condition Assessment of Aged Transformer Bushing Insulations, *CIGRE 2006*
- [10] Bica, M., *Thermotechnics and heat engines*, Universitaria Publishing House, Craiova, 2000
- [11] Zalewski, J., Izolacja przekładników prądowych na napięcia 220 i 400 kV, *PET* (1962), no 7, pages 273-281
- [12] \*\*\* Cosmos M.2.6. User guide, Structural Research and Analysis Corporation, Los Angeles, California, 2000
- [13] \*\*\* SolidWorks. User guide, Structural Research and Analysis Corporation, Los Angeles, California, 2004
- [14] Arnim Nethe, Thomas Scholz, Hanns-Dietrich Stahlmann, Ferrofluid driven electric motors – heat budget and experimental verification, *Workshop for ferrofluids, Benediktbeuern, 2000*
- [15] M.Timko, P.Kopcansky, K.Marton, L.Tomco, Dielectric properties of magnetic fluid, *Institute of Experimental Physics Slovak Academy of Sciences-Kosice, Faculty of Electrical Engineering and Informatics – Kosice, Faculty of Aviation - Kosice*

CV Silvius-Dorel Nedelcut:

[www.icmet.ro/cv\\_nedelcut.htm](http://www.icmet.ro/cv_nedelcut.htm)