

The influence of the valve lift strategies on the combustion characteristics of a homogeneous charge compression ignition engine model

Radu Cosgarea, Mihai Aleonte and Corneliu Cofaru

Abstract—This paper presents the results of the simulations made to investigate the influence of the burned gases trapped in the cylinder at the end of the exhaust stroke on the start of the auto ignition process and on the combustion characteristics of a homogeneous charge compression ignition (HCCI) engine. Different quantities of trapped burned gasses, used to control the auto ignition timing, were obtained by displacing the valve lifts. The cylinder pressure, cylinder temperature, heat release rate and mass fraction burned are calculated and compared.

Keywords—Cam phasers, gas trapping, homogeneous charge compression ignition engine.

I. INTRODUCTION

THE HCCI engines combine the compression ignition from the diesel engines with the homogeneous charge from the gasoline engines. Unlike the conventional engines, there is no direct mechanism to initiate the combustion, like the spark in the gasoline engines or the start of injection in the diesel engines. The auto ignition has to be controlled using indirect methods which affect the time-temperature history of the charge or the chemical properties of the fuel. The first method is most common and it is obtained using one or a combination of the following strategies: the variable compression ratio (VCR), internal or external exhaust gas recirculation (EGR), burned gas trapping or controlling the temperature of the intake air. The first three strategies have a faster response but they need more complex and expensive mechanisms. The fourth strategy, due to the slow response is used only in some

laboratory experiments.

In the last decades many researchers used different strategies were used to obtain the homogeneous combustion. The first tests were made using two-stroke engines [7]. Many names were used, Active Thermo-Atmosphere Combustion (ATAC) [8], Premixed Lean Diesel Combustion (PREDIC) [9], Uniform Bulky Combustion System (UNIBUS) [11], Controlled Auto-Ignition (CAI) [7], but in the last period the acronym HCCI is used.

The internal EGR and the burned gas trapping method are very similar. In both cases, the quantity of the burned gases which are used to control the auto ignition timing is controlled with the valve lift system. The burned gas trapping method is obtained by closing the exhaust valve before the top dead center (TDC) and opening the intake valve after the TDC. The burned gases trapped inside the cylinder are compressed. To control the valve timings a mechanism with a cam phaser has to be used by the motion of the piston to the TDC. The valve lift strategy used to trap the burned gases is shown in figure 1. When the burned gases trapping method is used, the intake and exhaust valve overlap disappears.

In the case of the internal EGR the exhaust valve have to be open during a part of the intake process. A part of the burned gases are reintroduced back into the cylinder.

Manuscript received May 16, 2011; Revised version received . This paper is supported by the Sectorial Operational Programme Human Resources Development (SOP HRD), financed from the European Social Fund and by the Romanian Government under the contract number POSDRU/6/1.5/S/6.

R. Cosgarea is with the D02 High-Tech Products for Automotives Department, Transilvania University of Brasov, Brasov, 500024, Romania National Institute of Standards and Technology, Boulder, CO 80305 USA (phone: 0040-728-144780; fax: 0040-268-474761; e-mail: radu.cosgarea@unitbv.ro).

M. Aleonte is with the D02 High-Tech Products for Automotives Department, Transilvania University of Brasov, Brasov, 500024, Romania National Institute of Standards and Technology, Boulder, CO 80305 USA (e-mail: mihai.aleonte@unitbv.ro).

C. Cofaru is with the D02 High-Tech Products for Automotives Department, Transilvania University of Brasov, Brasov, 500024, Romania National Institute of Standards and Technology, Boulder, CO 80305 USA (e-mail: ccomel@unitbv.ro).

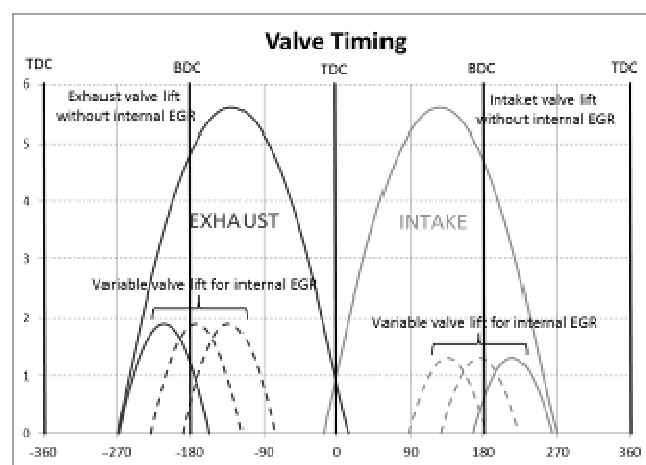

Fig. 1 valve timings

II. THE ENGINE MODEL

The simulations were made using the AVL Boost, an advanced and fully integrated “Virtual Engine Simulation Tool”.

The HCCI engine model is presented in figure 2. The model is made from the two system boundaries SB1 and SB2, the air cleaner CL1, the intake pipes 1, 2, 3 and 4, the two plenums PL1 and PL2, the cylinder C1, the exhaust pipes 5, 6, 7, 8 and the catalyst CAT1. Four measuring points are used, two on the intake pipes (one between the air cleaner CL1 and the plenum PL1 and the other between the plenum PL1 and the cylinder C1) and two on the exhaust pipes (one between the cylinder C1 and the plenum PL2 and the other between the plenum PL2 and the catalyst CAT1).

The air filter and the catalyst are used only to simulate the gasdynamic losses and the pressure drop over depending on the gas flow from the intake and the exhaust circuits.

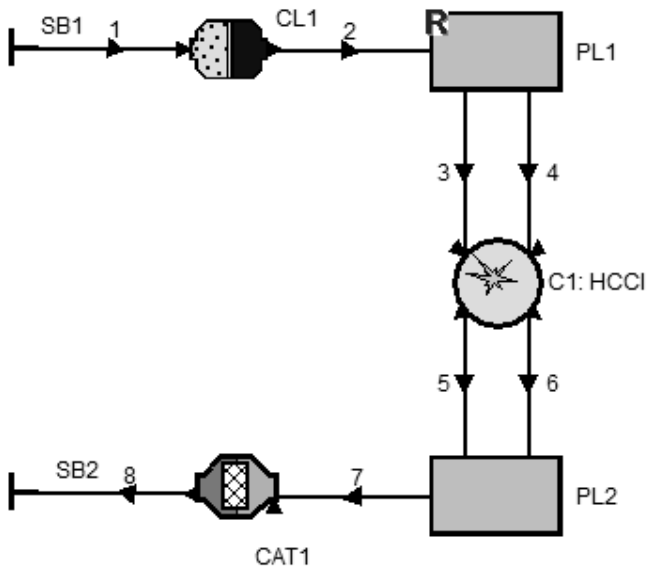

Fig. 2 the engine model

The air is introduced from the atmosphere and is passing through the pipe 1, air cleaner CL1, pipe 2 and it enters in the plenum PL1. From the plenum PL1 2 pipes, 3 and 4 are leading and entering to the cylinder C1. The burned gases are leaving the cylinder C1 and are entering in the plenum PL2 using two pipes, 5 and 6. From the plenum PL2 the exhaust gases are passing through the pipe 7, the catalyst CAT1 and the pipe 8 before its going in the atmosphere.

The variable valve timing mechanism (cam phasers) is simulated using different (displaced) intake and exhaust valve lifts.

The engine model is design to study only the influence of the valve timing. The engine characteristics may differ from the experimental results. The specifications of the single cylinder engine model used for the simulations are shown in

table I.

Engine type	HCCI	-
Fuel	Gasoline	-
Displacement	652	cm ³
Compression ratio	11.5:1	-
Bore	100	mm
Stroke	83	mm
Con-rod length	149	mm
No. of valves	4 (2 for intake, 2 for exhaust)	-
Fuel system	Direct injection	-

Table I. The engine model specifications

III. THE VALVE TRAIN MODELING

The start of the combustion (SOC) is influenced by the temperature of the charge. When the temperature is higher the combustion starts earlier. The temperature of the charge is influenced by the amount of burned gases which are trapped in the cylinder at the end of the exhaust stroke. To obtain different amounts of burned gasses trapped in the cylinder, the moment when the exhaust valve is closing has to be changed. This can be achieved using variable valve train systems. Simple systems which are using cam phasers (Fig. 3) can fulfill the HCCI requirements [1]. The cam phasers have the ability to adjust camshaft position. The valve lift curve can be displaced forwards or backwards (Fig. 1) to obtain the amount of trapped gasses needed to control the auto ignition delay.

The exhaust valve lift is displaced to control the amount of burned gases which are maintained in the cylinder and compressed during the end of the exhaust stroke. The intake valve should open when the pressure from the intake manifold is similar with the pressure from the cylinder.

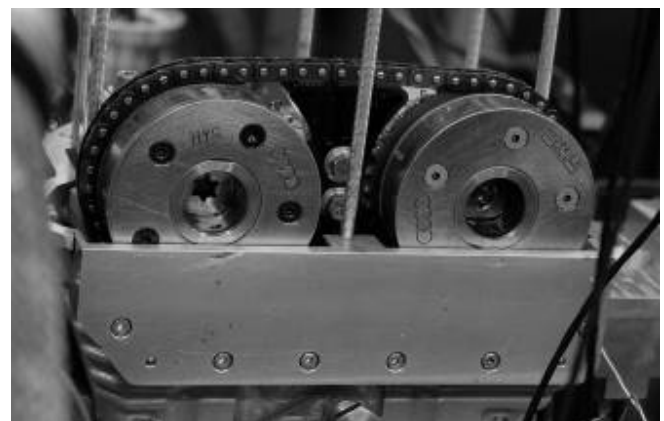

Fig. 3 cam phasers

When the exhaust valve is closing sooner, the compression of the trapped gases is higher so the intake valve has to be open later.

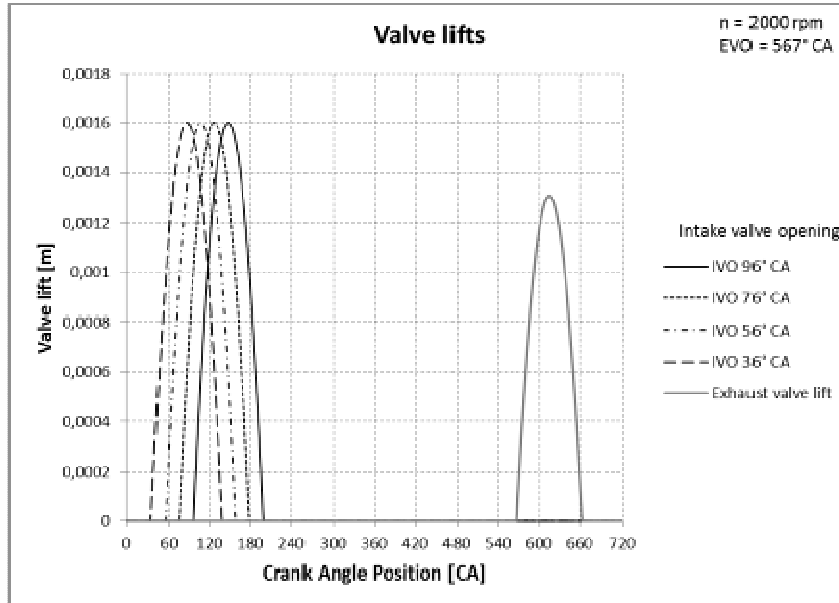

Fig. 4 valve lifts-variable intake

The best performances of the engine can be achieved by tuning of the intake valve lifts depending on the exhaust valve lifts.

The first four operating points are used to study the influence of the intake timing on the cylinder pressure. The exhaust valve opening (EVO) starts for all the operating points at 567° crank angle (CA). The intake valve opens (IVO) at 96° CA for the first operating point, at 76° CA for the second operating point, at 56° CA for the third operating point and at

36° CA for the fourth operating point (Fig. 4). For all the simulations the engine speed was maintained at 2000 rpm.

Figure 5 presents the evolution of the cylinder pressure depending on the crank angle position where the intake valve starts to open. The exhaust valve lift remains the same for all the four operating points. The valve timings can be observed on the secondary axis of the chart.

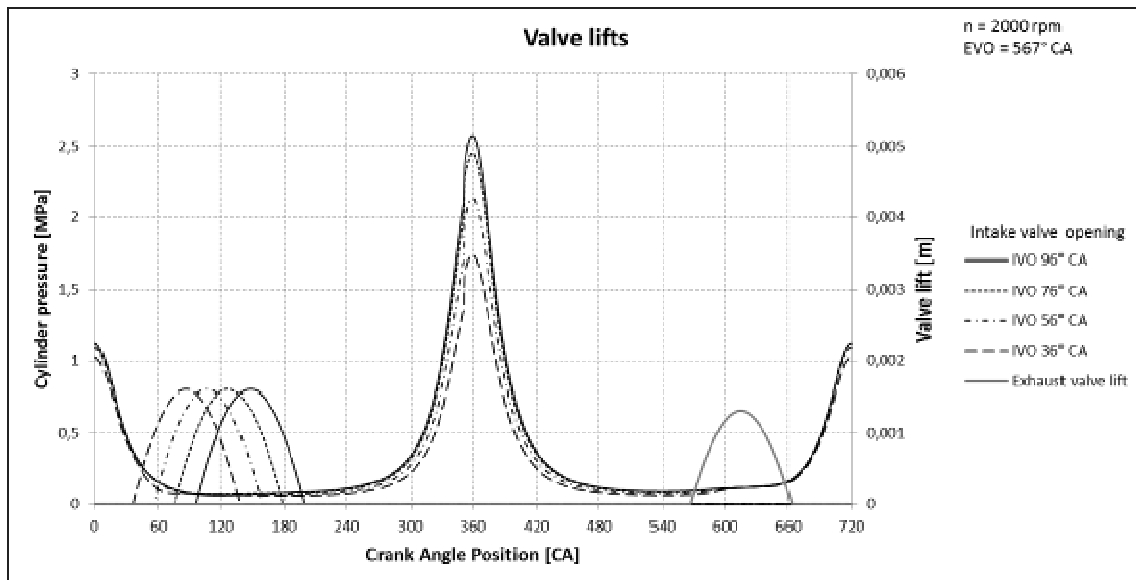

Fig. 5 the influence of the intake valve lift on the cylinder pressure

The influence of the intake valve lift on the cylinder pressure can be seen at the beginning of the intake process (Fig. 6) and during the combustion process (Fig. 7).

In fig. 6 the influence of the intake valve lift can be

observed. If the intake valve is opening earlier the pressure from inside the cylinder is higher than the pressure from the intake manifold and the. Due to the difference of the pressure, the burned gases are entering into the intake circuit and the

cylinder pressure drops. At the beginning of the admission process the burned gases are reintroduced in the cylinder

before the fresh air. Due to this, less air is introduced in the cylinder.

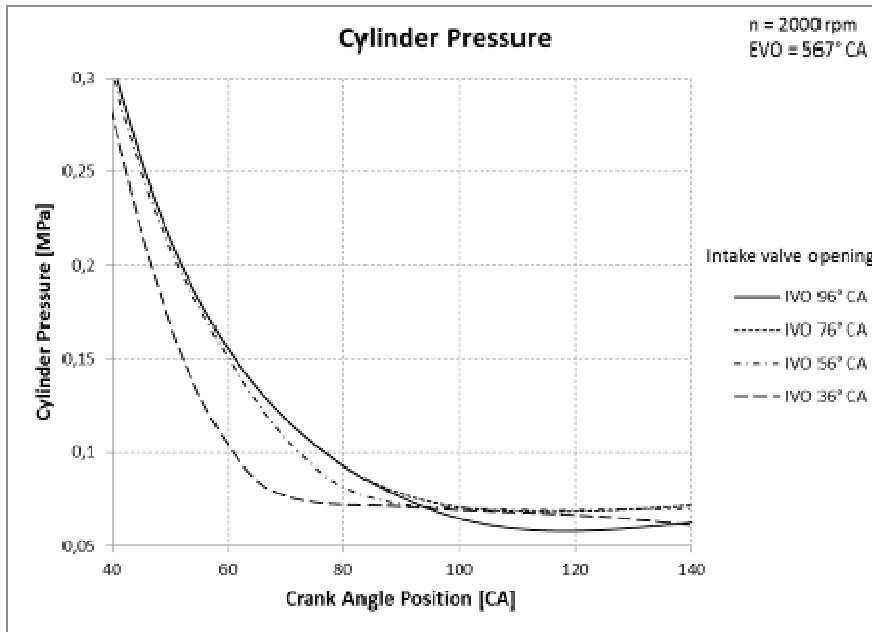

Fig. 6 the influence of the intake valve lift on the cylinder pressure during the intake stroke

In fig. 7 the influence of the intake valve timing on the cylinder pressure during the combustion process can be observed. When the intake valve opens earlier, due to the smaller quantity of air aspired the maximum pressure is decreasing. The moment when the intake valve is opened has to be choosing with a small advance before the cylinder

pressure reaches the intake manifold pressure. If the intake valve is opened when the cylinder pressure is smaller than the intake manifold pressure, the duration of the intake process will be shorter, less air will enter into the cylinder for the combustion process and the maximum pressure will drop.

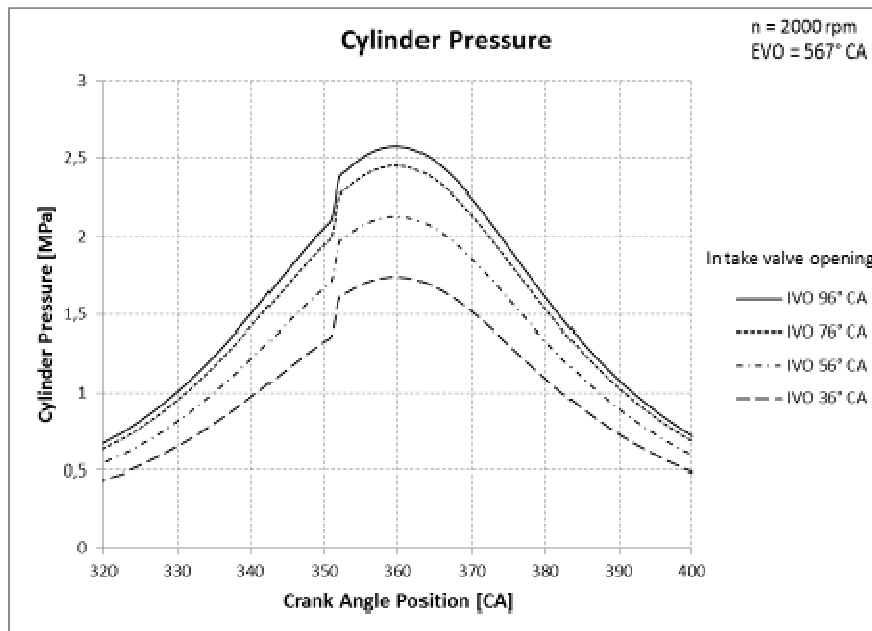

Fig. 7 the influence of the intake valve lift on the cylinder pressure during the combustion

In fig. 8 the valve lifts used to study the influence of the quantity of trapped burned gases on the cylinder pressure are

shown. Four operating points are used, where the intake valve lift is the same for all the operating points while the exhaust valve lift is displaced to simulate different quantities of trapped burned gases. The intake valve is opening at 76° CA and the exhaust valve is opening at 567° CA for the first operating point, at 587° CA for the second operating point, at

607° CA for the third operating point and at 627° CA for the last operating point.

The engine speed was maintained constant during all the measurements made on the four operating points at 2000 revolutions per minute (rpm).

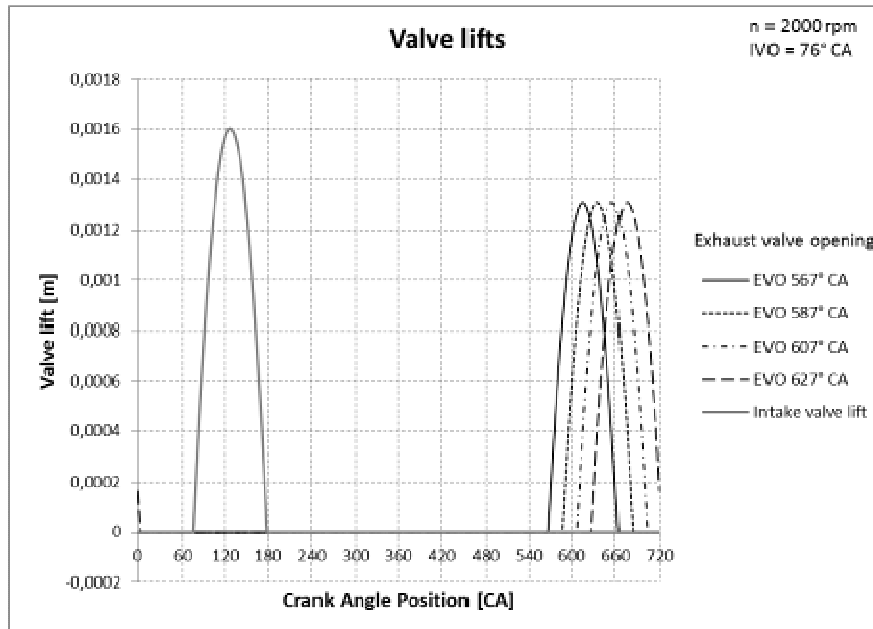

Fig. 8 valve lifts-variable exhaust for controlling the amount of trapped gasses

V. THE INFLUENCE OF THE BURNED GASES ON THE COMBUSTION CHARACTERISTICS

The internal burned gases trapped in the cylinder have four main effects on the combustion:

- the charge heating effect,
- the dilution effect,
- the heat capacity effect and
- the chemical effect.

The charge heating effect occurs because the burned gases have a very high temperature. The burned gases are mixed with the new charge and the temperature of the fresh charge is raised. This effect is important because it has a huge influence on the start of the combustion. The charge heating effect has four consequences (g):

- the combustion starts earlier,
- the maximum pressure is higher,
- the heat release rate is higher,
- the combustion duration is shorter.

The dilution effect occurs because the trapped burned gases are replacing a part of the inlet air. If the amount of air which is introduced into the cylinder is lower, the concentration of the oxygen (O_2) is reduced, so the burned gases have a dilution effect. The dilution effect does not influence the start of the combustion but has consequences on the combustion characteristics [3], [12]:

- the combustion duration is extended,
- the heat release rate is reduced.

The heat capacity effect occurs because of the water (H_2O) vapors and carbon dioxide (CO_2) from the burned gases. They have a higher specific heat capacity, so the total heat capacity of the mixture is increasing. The heat capacity effect has the following consequences:

- the temperatures of the charge at the end of the compression process and during the combustion are lower,
- the heat release rate is reduced [3], [5],
- the combustion duration is increased [1], [13].

The chemical effect occurs due to the active products that remain in the burned gases and participate at the chemical reactions which are leading to the combustion process. Due to the chemical effect the combustion can start earlier [4].

Figure 9 presents the evolution of the cylinder pressure depending on the quantity of burned gases trapped in the cylinder. On the secondary axis the intake and the exhaust valve lifts can be observed.

The cylinder pressure versus crank angle data over the compression and expansion strokes of the engine operating cycle are used to obtain information about the progress of combustion. It is a very important tool used to describe the evolution of the combustion and to calculate the evolution of the characteristics that can't be measured directly, like the cylinder temperature versus crank angle. The burned gases

influence may be observed in two zones: during the gas exchange (Fig. 10) and during the combustion (Fig. 11).

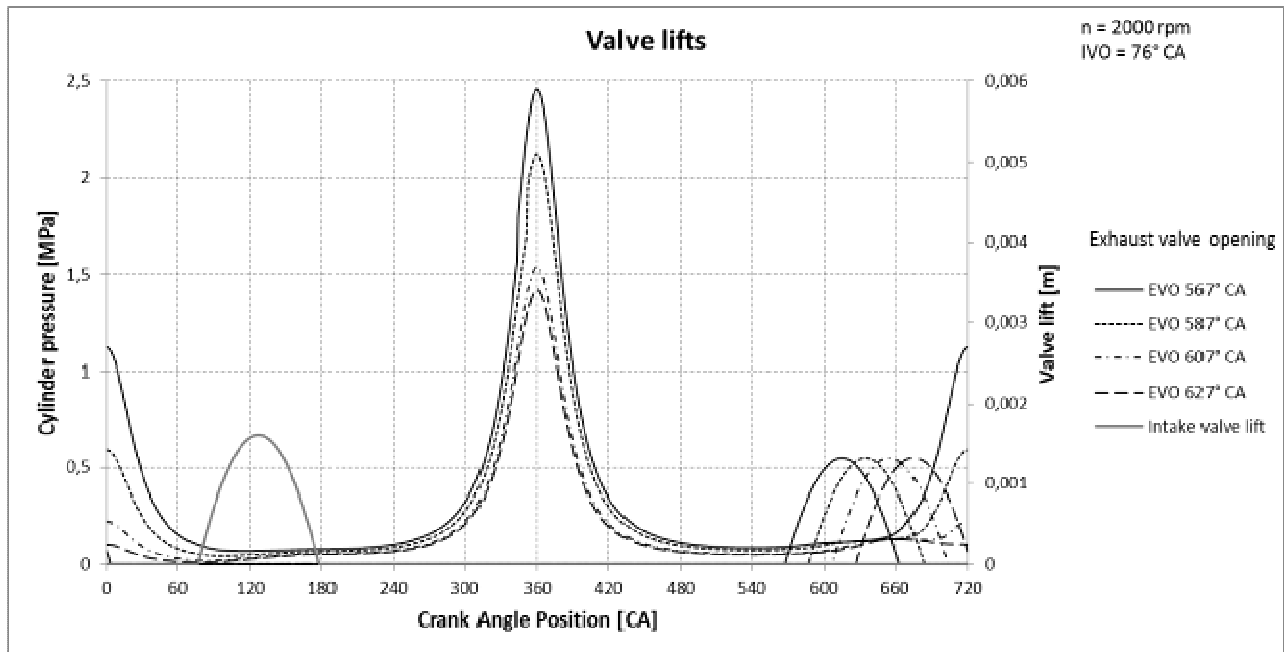

Fig. 9 the influence of the exhaust valve lift on the cylinder pressure

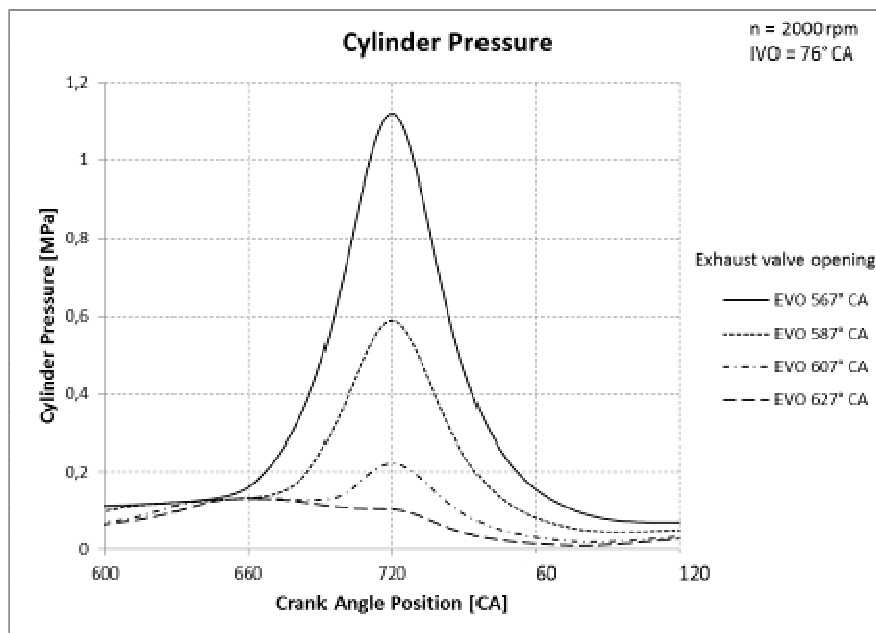

Fig. 10 the influence of the exhaust valve lift on the cylinder pressure during the intake stroke

The moment when the exhaust valve is closed has a huge influence on the cylinder pressure during the gas exchange, especially at the end of the exhaust stroke and on the beginning of the intake stroke. The moment when the exhaust valve is closed determines the place where the compression of the trapped gases begins.

The amount of the trapped burned gases determines the temperature of the intake charge. Due to the lack of a direct mechanism to initiate the combustion, the time temperature

history of the fresh mixture is very important.

If the intake valve is closing sooner (operating point 1, IVO 76° CA, EVO 567° CA), with a higher advance before the TDC, more gases are trapped into the cylinder at the end of the exhaust stroke and their compression starts earlier. Due to this, the pressures obtained during the end of the exhaust stroke and the beginning of the intake stroke is higher (Fig. 10), the temperatures are rising and the ignition occurs earlier (Fig. 11).

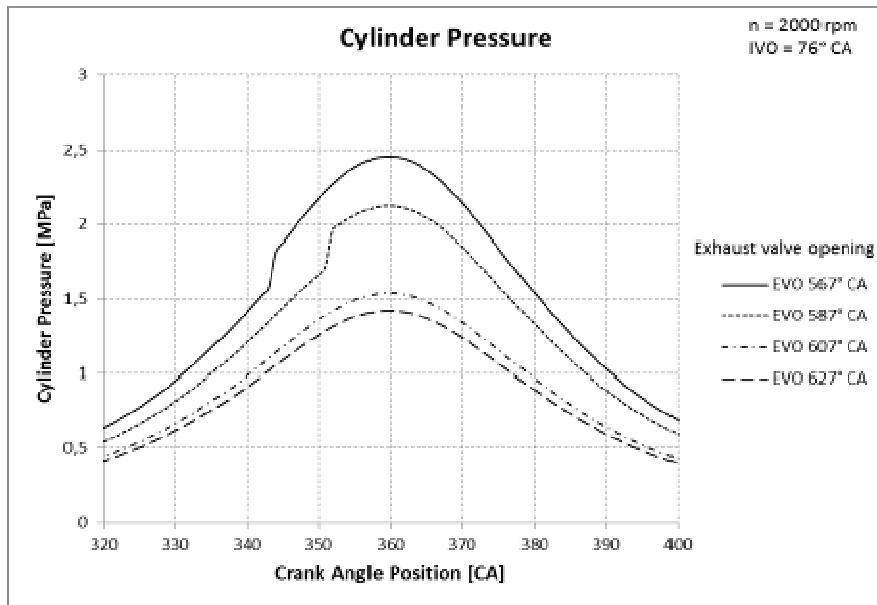

Fig. 11 the influence of the exhaust valve lift on the cylinder pressure during the combustion

If the exhaust valve is closing with a very small advance before the TDC (operating point 1, IVO 76° CA, EVO 60.7° CA), the amount of trapped gases at the end of the exhaust stroke is very low, the pressure during the end of the exhaust stroke and at the beginning of the intake stroke is too low (Fig. 10). Due to these facts, the temperatures during the compression stroke are too low and the conditions needed for the auto ignition are missing and no combustion will occur

(Fig. 11).

If the exhaust valve is closing with a delay after the TDC (operating point 4, IVO 76° CA, EVO 62.7° CA), no gases are trapped in the cylinder at the end of the exhaust stroke. There is no compression during the gas exchange process (Figure 10), the temperatures during the compression stroke are too low and the conditions needed for the auto ignition are missing so there will be no combustion (Fig. 11).

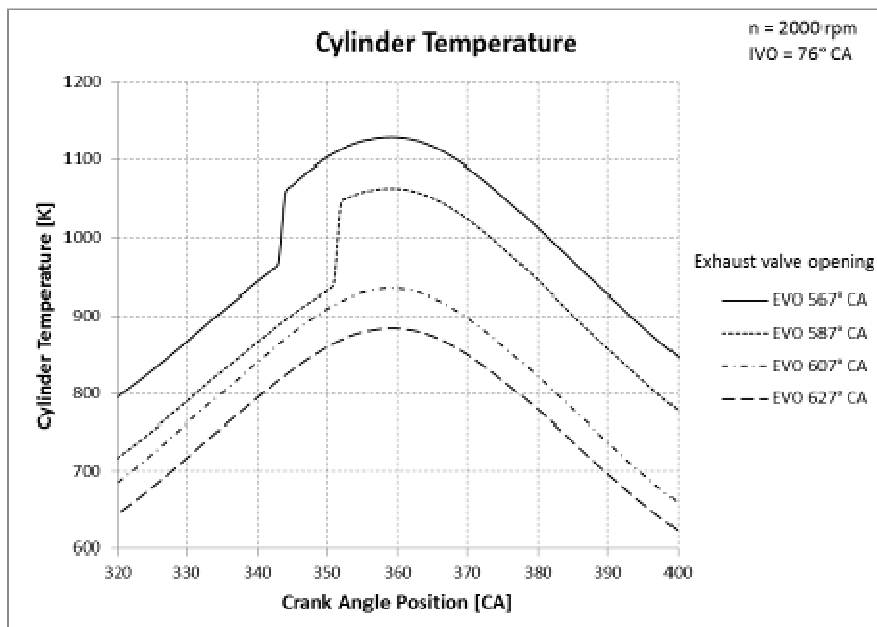

Fig. 12 the influence of the exhaust valve lift on the cylinder temperature during the combustion

The cylinder temperature (Fig. 12) is very important because it has a big influence on the nitrogen oxides (NO_x), unburned hydrocarbons (HC) and carbon monoxide (CO).

When the temperature is higher the NO_x emission formation is increasing. The HCCI engines are using lean mixtures and high quantities of burned gases, which are diluting the fresh

charge. The temperatures during the combustion are lower and the NO_x emissions are reduced up to 98% [2].

The CO emissions are very high at the HCCI engines. This can be explained due to the fact that the CO needs a temperature of about 1400-1500K to be oxidized in CO₂, temperatures that usually are not reached during the combustion.

If the temperatures during the combustion are low, the combustion is not extended during the expansion stroke and the unburned HC emissions are increasing.

In fig. 12 the evolution of the cylinder temperatures is presented. The heating effect of the burned gases can be observed during the compression process. When the exhaust valve is closing with a higher advance before the top dead center and more burned gases are trapped inside the cylinder the temperature of the fresh charge is increasing. Even when the combustion does not occur (measuring point 3, EVO 607°

CA and measuring point 4, EVO 627° CA) the influence of the hot gases can be observed. The temperature during the compression and the expansion stroke is higher for the third operating points due to the higher quantity of trapped gases from the cylinder.

When the combustion process occurs, the temperature is increasing (measuring point 1, EVO 567° CA and measuring point 2, EVO 587° CA). When the temperature is higher, the auto ignition of the fresh charge occurs earlier and a higher temperature is obtained. This leads to higher NO_x emissions, lower CO and HC emissions.

In fig. 13 the evolution of the heat release rate can be observed. For the first two operating points (EVO 567° CA and EVO 587° CA) the heat is released very fast. In the HCCI engines the combustion occurs in the whole charge in the same time causing a very fast heat release.

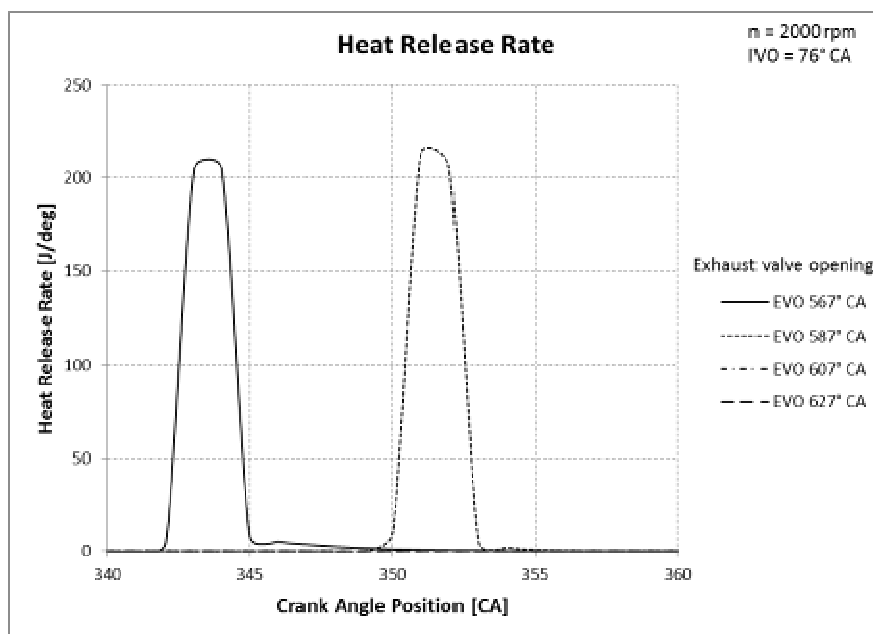

Fig. 13 the influence of the exhaust valve lift on the heat release rate

At the first operating point the heat starts to be released earlier, at about 342° CA. The main part of the fuel is burned during the interval 342-345° CA. Due to the higher temperatures and of the dilution effect of the burned gases, a part of the fuel is burned after the main heat release, in the interval 345-351° CA. This leads to lower unburned HC and CO emissions.

At the second point the heat starts to be released later. The combustion occurs closer to the TDC, between 350-353° CA and the heat is released faster. The lower quantity of the burned gases from the fresh charge is decreasing the dilution effect. Due to the lower temperatures, less fuel is burned after the main heat release. The unburned HC and the CO emissions are increased.

For the second point, the heat release rate is higher compared with the first point. This can be explained due to the fact that the combustion occurs closer to the top dead center.

For the last two operating points the heat release rate is null. When the quantity of burned gases is too low or when no burned gases are trapped inside the cylinder the conditions needed for the auto ignition of the fresh mixture are missing.

The mass fraction burned (MFB) for every engine cycle is a normalized quantity with a scale from 0 to 1 (0 before the combustion started, 1 after all the fuel was burned during the combustion). It is used to describe the chemical energy release process as a function of crank angle [6]. It is calculated using the heat release rate diagram.

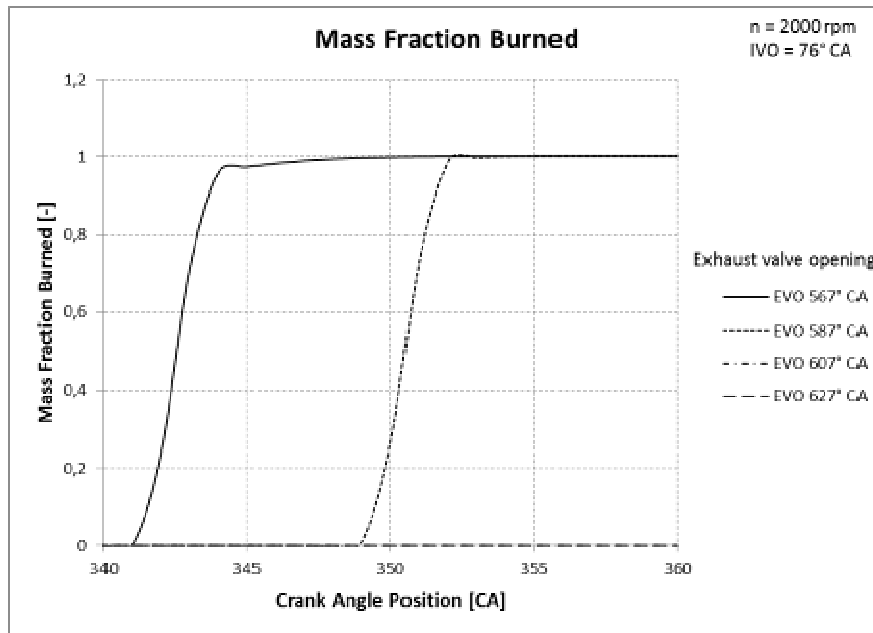

Fig. 14 the influence of the exhaust valve lift on the heat release rate

Figure 14 shows the evolution of the mass fraction burned. At the last two operating points, because the combustion does not occur, the mass fraction burned is null.

For the first two operating points the evolution of the mass fraction burned is similar. The combustion process is very fast, the main part of the fuel is burned during the main phase of the combustion. The burning speed of the fuel is proportional with the slope of the mass fraction burned traces. When no fuel is burning, the mass fraction burned trace is horizontal.

For the first operating point (EVO 567° CA) the combustion occurs at 342° CA. In the first phase of the combustion the burning speed is very high (98% of the fuel mass is burned during 3° CA). At the beginning the burning speed is increasing, until 10% of the fuel mass is burned, than the burning speed is maintained constant. After 70% of the fuel mass is burned, the combustion speed is decreasing slowly. During the second phase the burning speed is decreasing. The rest of the fuel mass is burned during 6° CA (the slope of the

MFB trace is almost horizontal).

At the second operating point only a negligible part of the fuel mass is burned during the second stage. The evolution is similar with the combustion during the first stage of the measuring point 1 (the speed is increasing, afterwards is maintained constant and in the end is decreasing slowly).

VI. THE INFLUENCE OF THE VALVE LIFT STRATEGY ON THE PUMPING LOSSES

The valve lift strategy has also a big influence during the gas exchange process on the pumping losses. The moment when the exhaust valve is closing determinates the amount of burned gases which are trapped in the cylinder and compressed during the end of the exhaust stroke.

For the influence of the valve lift strategy on the pumping losses only three measuring points have been used. In table II the parameters used during the simulations can be observed.

Point	Engine speed	Intake valve opening	Intake valve closing	Exhaust valve opening	Exhaust valve closing
[-]	[rpm]	[°CA]	[°CA]	[°CA]	[°CA]
1	2000	76	183	567	668
2	2000	76	183	587	688
3	2000	76	183	627	8

Table II. The engine model parameters

The results of the simulations can be seen in figure 15 (the pumping losses diagram). When the exhaust valve is closing with a delay after the TDC (no burned gases are trapped in the cylinder) the pumping losses are higher.

The quantity of the work lost during the pumping losses is determinate by the area of the pumping diagram. The area was

calculated using the trapezoidal rule.

To use the trapezoidal rule the area has to be split in a number of intervals. The error is decreasing if the number of the intervals is higher. Each interval has the shape of a trapeze. The work lost during the pumping losses is the some of all areas of all the trapezes [10].

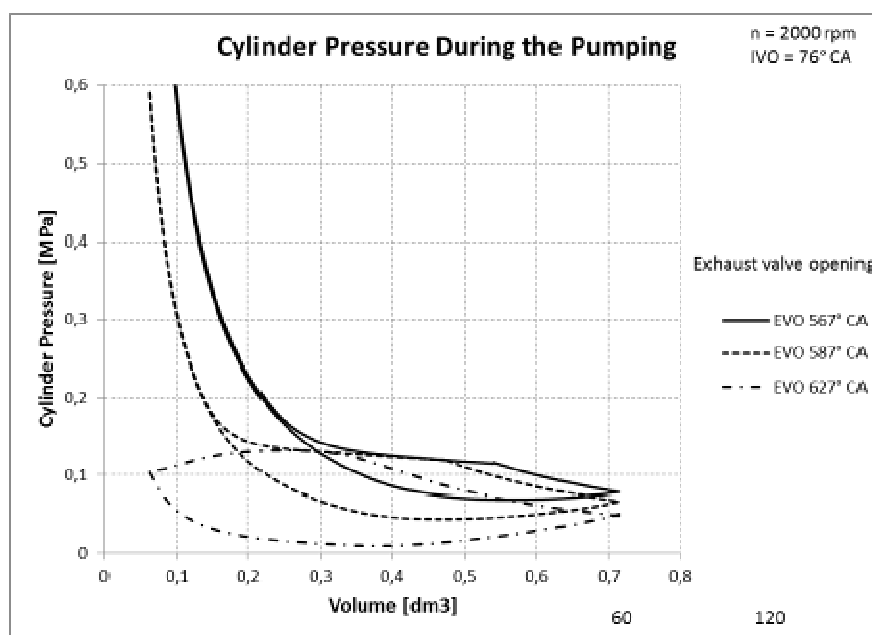

Fig. 15 the influence of the exhaust valve lift on the pumping losses

For the first operating point (EVO 567° CA) the pumping losses are lower. The losses during the compression of the burned gases at the end of the exhaust stroke and during the expansion of the burned gases at the beginning of the intake stroke are very small. The pressure trace during the compression of the burned gases is overlapped on the pressure during the expansion of the burned gases.

Small work losses during the compression and expansion of the burned gases can appear due to the difference of temperature between the gases and the temperature of the cylinder wall. The temperature of the compressed burned gases is higher than the temperature of the wall, so a part of the heat of the gases is transferred to the cylinder walls. The heat transfer depends on the combustion chamber design, area and surface, on the materials used at its construction and on the duration of the transfer (the engine speed).

Another loss of work can appear due to the leakage of the burned gases from the combustion chamber to the crankcase. In this case only the engine speed affects the losses.

In the second operating point (EVO 587° CA) the pumping losses are higher. The exhaust valve is close later and the intake process is starting earlier, due to the lower pressure from the cylinder. More burned gases are passing through the exhaust valve and more fresh air is introduced in the cylinder through the intake valve. Due to this facts, the gasdynamic losses are increasing.

For the last operating point (EVO 627° CA) the gasdynamic losses are very high. The exhaust valve is closed after the top dead center, so the burned gases are not trapped anymore in the cylinder. All the gases are pushed out from the cylinder and the gasdynamic losses are increased. After the exhaust valve is closed, the pressure from the cylinder is

decreasing due to the piston movement from the top dead center to the bottom dead center. When the intake valve is opened the difference of the pressure between the cylinder and the intake manifold are higher. The new charge is entering in the cylinder with a higher speed, increasing the gasdynamic losses.

The combustion from the gasoline HCCI engines can be controlled modifying the amount of trapped gases maintained in the cylinder or the amount of burned gases reintroduced in the cylinder. Based on the research of the influence of the valve lift strategy on the pumping losses the best method can be choose.

In figure 16 the pumping work lost during the three operating points is presented. The difference from the three points is very significative. The results are showing that the gasdynamic losses during the exhaust process and during the intake process are higher than the work losses during the compression and the expansion of the trapped gases.

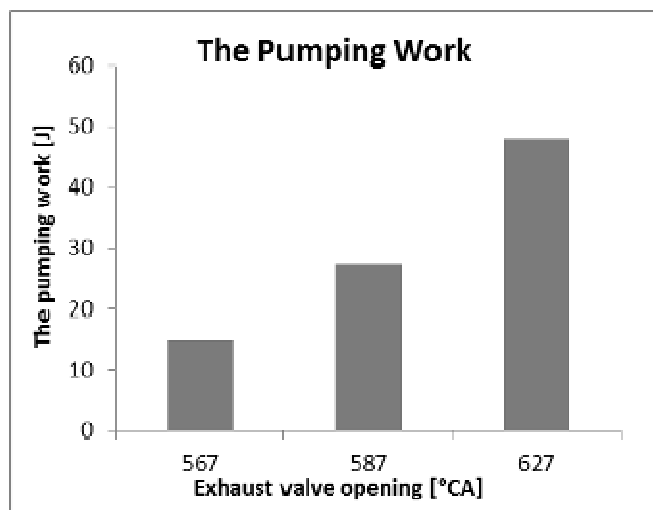

Fig. 16 the pumping work

In figure 17 the evolution of the pumping work depending on the moment when the exhaust valve is closed can be observed. It can be observed that the pumping work is increasing linear with the decreasing of the advance of the exhaust valve closing to the top dead center.

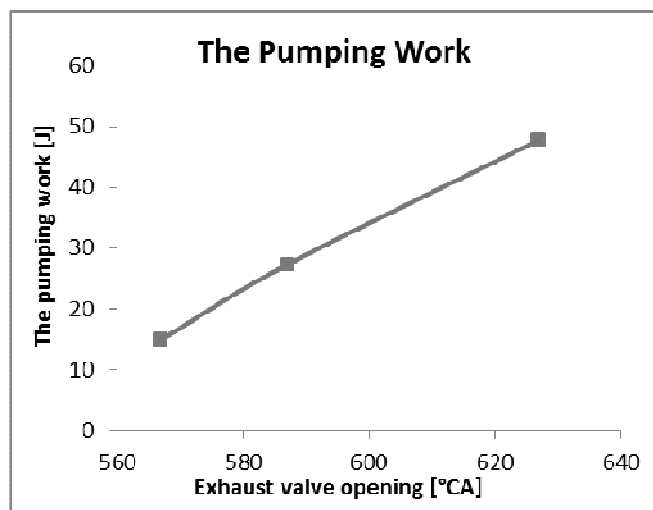

Fig. 17 the pumping work

VII. CONCLUSION

The valve train system has a higher importance at the HCCI engines. Beside its main purpose, to ensure the exhaust of the burned gases and the intake of the fresh air, the valve train system has to ensure the conditions needed to obtain the homogeneous combustion and also to control the auto ignition delay. Due to this task, more complex mechanisms capable of modifying the valve lifts while the engine is running are used.

The best performances of the engine can be achieved when the intake valve lifts are fine tuned depending on the exhaust valve lifts. The main objective is to ensure the proper timing for the opening of the intake valve when the pressure from the intake manifold is similar with the cylinder pressure. The best

timing is obtained when no burned gases from the cylinder are passing into the intake manifold and the maximum quantity of air is aspirated during the intake process.

The amount of trapped burned gases has a huge influence on the combustion. When the quantity of trapped burned gases is too low the conditions needed for the auto ignition of the air-fuel mixture are missing so there will be no combustion. On the other hand, the trapped gases are replacing a part of the fresh air which can be aspirated into the cylinder so the performances of the engine can be reduced using a high quantities of trapped burned gases.

The increase of the quantity of burned trapped gases leads to lower pumping losses due to the lower gasodynamic losses during the gas exchange process (less gases are passing through the intake and exhaust valves).

ACKNOWLEDGMENT

This paper is supported by the Sectorial Operational Programme Human Resources Development (SOP HRD), financed from the European Social Fund and by the Romanian Government under the contract number POSDRU/6/1.5/S/6.

REFERENCES

- [1] Baumgarten, C., *Mixture Formation in Internal Combustion Engine*, Springer, 2006
- [2] Duret P., Gatellier B., Miche M., Montreiro L., Zima P., Marotax D., Blundell D., Ganser M., Zhao H., Perozzi M., Araneo L., "Innovative Diesel HCCI Combustion", EAEC European Automobile Engineers Cooperation Congress no. 9, p 57-68, 2003
- [3] Groenendijk A., Müller E. "Mixture Formation and Combustion Control for Low Emission DI Diesel Combustion with HC-CI-Characteristics". THIESEL 2002, Valencia, 10th-13th September 2002, pp 145-157
- [4] Ishibashi Y., Asai M., "Improving the Exhaust Emission of Two-Stroke Engines by Applying the Activated Radical Combustion". SAE paper 960742, 1996
- [5] Law D., Allen J. "On the Mechanism of Controlled Auto Ignition". SAE paper 2002-01-0421, 2002
- [6] Mendera K. Z., Spyra, A., Smereka, M., "Mass Fraction Burned Analysis", Journal of KONES Internal Combustion Engines, No. 3-4, 2002, p193-201
- [7] Oakley A., Zhao H., Ladommatos N., Ma T., "Experimental Studies on Controlled Auto-Ignition (CAI) Combustion of Gasoline in a 4-Stroke Engine", Society of Automotive Engineers, SAE paper no. 2001- 01-1030, 2001
- [8] Onishi S., Jo S.H., Shoda K., Jo P.D., Kato S., "Active Thermo-Atmosphere Combustion (ATAC) – A New Combustion Process for Internal Combustion Engines", Society of Automotive Engineers, SAE paper no. 790501, 1979
- [9] Takeda Y., Keiichi N., Keiichi N., Emission Characteristics of Premixed Lean Diesel Combustion with Extremely Early staged Fuel Injection, Society of Automotive Engineers, SAE paper no. 961163, 1996
- [10] "The Trapezoidal Rule". Available at: http://pages.pacificcoast.net/~cazelais/187/trapezoidal_rule.pdf. Accessed: 27.03.2011
- [11] Yanagihara H., "Ignition Timing Control at TOYOTA "UNIBUS" Combustion System", A New Generation of Engine Combustion Processes for the Future, 2011, p 35-42
- [12] Zhao H., Peng Z., Milliams J., Ladommatos N., "Understanding the Effects of Recycled Burnt Gases on the Controlled Autoignition (CAI) Combustion in Four-Stroke Gasoline Engines". SAE paper 2001-01-3607, 2001
- [13] Zhao, H. *HCCI and CAI engines for the automotive industry*, Woodhead Publishing Limited, 2007